



OPERATION AND SERVICE MANUAL

8447D 8447E 8447F AMPLIFIER 0.1—1300 MHz

SERIAL NUMBERS

This manual applies directly to instruments with the following serial number prefixes:

8447D: 1937A

8447E: 1937A

8447F: 1937A

With changes described in MANUAL BACK-DATING CHANGES, this manual also applies to instruments with serial numbers prefixed 0933A, 1145A, 1529A, 1616A, 1644A, 1726A.

For additional important information about serial numbers, see INSTRUMENTS COVERED BY MANUAL.

Copyright © 1973, 1980, HEWLETT-PACKARD COMPANY
1400 FOUNTAIN GROVE PARKWAY, SANTA ROSA, CALIFORNIA, 95404, U.S.A.

SAFETY CONSIDERATIONS

GENERAL

This product and related documentation must be reviewed for familiarization with safety markings and instructions before operation. This product has been designed and tested in accordance with international standards.

SAFETY SYMBOLS



Instruction manual symbol: the product will be marked with this symbol when it is necessary for the user to refer to the instruction manual (refer to Table of Contents).



Indicates hazardous voltages.



Indicates earth (ground) terminal.

WARNING

The WARNING sign denotes a hazard. It calls attention to a procedure, practice, or the like, which, if not correctly performed or adhered to, could result in personal injury. Do not proceed beyond a WARNING sign until the indicated conditions are fully understood and met.

CAUTION

The CAUTION sign denotes a hazard. It calls attention to an operating procedure, practice, or the like, which, if not correctly performed or adhered to, could result in damage to or destruction of part or all of the product. Do not proceed beyond a CAUTION sign until the indicated conditions are fully understood and met.

SAFETY EARTH GROUND

This is a Safety Class I product (provided with a protective earthing terminal). An uninterruptible safety earth ground must be provided from the main power source to the product input wiring terminals, power cord, or supplied power cord set. Whenever it is likely that the protection has been impaired, the product must be made inoperative and be secured against any unintended operation.

BEFORE APPLYING POWER

Verify that the product is configured to match the available main power source per the input power configuration instructions provided in this manual.

If this product is to be energized via an autotransformer make sure the common terminal is connected to the neutral (grounded side of mains supply).

SERVICING

WARNING

Any servicing, adjustment, maintenance, or repair of this product must be performed only by qualified personnel.

Adjustments described in this manual may be performed with power supplied to the product while protective covers are removed. Energy available at many points may, if contacted, result in personal injury.

Capacitors inside this product may still be charged even when disconnected from its power source.

To avoid a fire hazard, only fuses with the required current rating and of the specified type (normal blow, time delay, etc.) are to be used for replacement.

1. GENERAL INFORMATION

2. The HP Models 8447D, 8447E and 8447F are general purpose, wideband amplifiers. Each instrument consists of a power supply and one or two thin film, hybrid, integrated circuit amplifiers. The thin film amplifiers are hermetically sealed and feature low noise, low distortion, flat frequency response, and long term stability and reliability.

3. The HP Model 8447D Amplifier is a pre-amplifier that provides 26 dB of gain to signals from 100 kHz to 1.3 GHz. It can be used to increase the sensitivity of any lab, shop or field device operating within its frequency range.

4. The HP Model 8447E Amplifier is a power amplifier that provides 22 dB of gain to signals from 100 kHz to 1.3 GHz. It can be used to increase the output power of signal generators, sweepers and similar devices operating within its frequency range.

5. The HP Model 8447F Amplifier contains a preamplifier and a power amplifier — the same thin film amplifiers used in the HP 8447D and HP 8447E. The input and output ports of both amplifiers are available on the front panel; they can be used separately or cascaded to provide 48 dB of gain.

Table 1. Specifications

	8447D	8447E	8447F	
	PRE AMP	POWER AMP	PRE AMP	POWER AMP
Frequency Range	0.1 to 1300 MHz	0.1 to 1300 MHz	0.1 to 1300 MHz	0.1 to 1300 MHz
Typical 3 dB Bandwidth	.05 to 1400 MHz	.05 to 1400 MHz	.05 to 1400 MHz	.05 to 1400 MHz
Mean Gain (20° - 30°C)	25 dB Minimum	22 dB \pm 1.5 _{2.0} dB	25 dB Minimum	22 dB \pm 1.5 _{2.0} dB
Gain Flatness Across Full Frequency Range	\pm 1.5 dB	\pm 1.5 dB	\pm 1.5 dB	\pm 1.5 dB
Noise Figure	< 8.5 dB	< 11 dB (Typical)	< 8.5 dB	< 11 dB (Typical)
Output Power for 1 dB Gain Compression	>+7 dBm (Typical)	>+15 dBm	>+7 dBm (Typical)	>+1 4 dBm
Harmonic Distortion	-30 dB for 0 dBm output (Typical)	-30 dB for +10 dBm output	-30 dB for 0 dBm output (Typical)	-30 dB for +10 dBm output
Typical Output for < -60 dB Harmonic Distortion	-30 dBm	-20 dBm	-30 dBm	-20 dBm
VSWR, 1 to 1300 MHz	< 2.0 INPUT < 2.2 OUTPUT	< 2.2	< 2.0 INPUT < 2.2 OUTPUT	< 2.2
Impedance	50 Ω	50 Ω	50 Ω	50 Ω
Reverse Isolation	> 40 dB	> 40 dB	> 40 dB	> 40 dB
Maximum DC Voltage Input	\pm 10 V	\pm 10 V	\pm 10 V	\pm 10 V
Typical Risetime	400 psec	420 psec	400 psec	420 psec
Typical Group Delay	1.1 nsec*	1.5 nsec**	1.1 nsec*	1.5 nsec**

Table 1. Specifications (Cont'd)

	8447D PRE AMP	8447E POWER AMP	8447F	
			PRE AMP	POWER AMP
Net Weight;	3 lbs., 8 oz. (1,59 kg.)	3 lbs., 8 oz. (1,59 kg.)	3 lbs., 14 oz. (1,75 kg.)	
Option 001	3 lbs., 14 oz. (1,75 kg.)	_____	_____	_____
Option 010	3 lbs., 10 oz. (1,64 kg.)	3 lbs., 10 oz. (1,64 kg.)	4 lbs., 1 oz. (1,84 kg.)	
Option 011	4 lbs., 1 oz. (1,84 kg.)	_____	_____	_____
Dimensions	8-1/2 inches (216 mm) by 5-1/8 inches (130 mm) by 3-3/8 inches (85, 8 mm)			
Power Requirements	115 or 230 Vac $\pm 10\%$, 48 to 440 Hz, 15 Watts, 27 VA max.			
<p>* Variation over any 50 MHz band from 0.1 — 1300 MHz is typically < 0.15 nsec.</p> <p>**Variation over any 50 MHz band from 0.1 — 1300 MHz is typically < 0.25 nsec.</p>				

6. OPTIONS

7. The HP Model 8447D is a single preamplifier with BNC connectors. However, to provide flexibility, three options are offered:

- a. Option 001 — dual preamplifier, BNC connectors.
- b. Option 010 — single preamplifier, Type N connectors.
- c. Option 011 — dual preamplifier, Type N connectors.

8. The HP Model 8447E is a power amplifier with BNC connectors; one option is offered: Option 010 — Type N connectors.

9. The HP Model 8447F is a preamplifier and a power amplifier with BNC connectors; one option is offered: Option 010 — Type N connectors.

NOTE

All dual amplifier options with Type N connectors are furnished with a rigid coaxial cable (W6) that can be used to cascade the amplifiers with minimum loss.

10. INSTRUMENTS COVERED BY MANUAL

11. This manual fully documents the HP 8447D, HP 8447E and the HP 8447F. Any references in the manual apply to all three amplifiers unless otherwise noted.

12. Each amplifier has a ten digit serial number on the serial plate on the rear panel; the first five digits of the serial number are a prefix. The contents of this manual apply directly to instruments with the same serial number prefix as listed after SERIAL NUMBERS on the inside title page.

13. Revisions required to adapt the manual to other serial number prefixes are contained in a yellow "Manual Changes" insert supplied with the manual. For information about serial number prefixes not listed on the title page or in the insert, contact your nearest Hewlett-Packard office.

14. INITIAL INSPECTION

15. Mechanical Check

16. If damage to the shipping carton is evident, ask the carrier's agent to be present when the instrument is unpacked. Inspect the instrument for mechanical damage. Also check the cushioning material for signs of severe stress.

17. Performance Check

18. The electrical performance of an amplifier should be verified upon receipt. Performance checks suitable for incoming inspection are given in paragraphs 55 through 58.

19. Claims for Damage

20. If the instrument is mechanically damaged in transit, notify the carrier and the nearest Hewlett-Packard field office immediately. A list of field offices is contained in the back of this manual. Retain the shipping carton and padding material for the carrier's inspection. The field office will arrange for replacement or repair of your instrument without delay for claim settlements against the carrier. Before shipment, this instrument was inspected and found free of mechanical and electrical defects. If there is any deficiency, or if electrical performance is not within specifications, notify your nearest Hewlett-Packard sales and service office.

21. PREPARATION FOR USE

22. Power Requirements

23. The amplifier operates from 115 or 230 volts ac line voltage at any line frequency between 48 and 440 Hz. A slide switch on the rear panel is set to the correct position for the line voltage available.

24. Power Cable

25. To protect operating personnel, the National Electrical Manufacturer's Association (NEMA) recommends that the instrument panel and cabinet be grounded. All Hewlett-Packard instruments are equipped with a three-conductor power cable which, when plugged into the appropriate receptacle, grounds the instrument. The offset pin on the power cable's three-prong connector is the ground wire. The power cord and power input connector meet the specifications established by the International Electrotechnical Commission (IEC).

26. Mating Connectors

27. Mating connectors used with the amplifier should be 50-ohm type BNC male. If the amplifier has the optional Type N connectors, use Type N male connectors that are compatible with US MIL-C-39012.

28. Operating Environment

29. The operating range of the amplifier is from 0°C to +55°C. The amplifier can be stored in a temperature range of -40°C to +75°C.

30. Bench Mounting

31. The amplifier is equipped with plastic feet and tilt stand in place, ready for use as a bench instrument.

32. Rack Mounting

33. The amplifier may be rack mounted by using an adapter frame. The adapter frame is a rack frame that accepts several combinations of sub-modular units. For additional information, address inquiries to your nearest Hewlett-Packard sales and service office.

34. STORAGE AND SHIPMENT

35. Packaging

36. The following paragraphs contain a general guide to repackaging of the instrument for shipment. Refer to paragraph 38 if the original container is to be used; refer to paragraph 40 if it is not.

37. If the instrument is to be shipped to Hewlett-Packard for service or repairs, attach a tag to the instrument identifying the owner and indicating the service or repair required; include the model number and full serial number of the instrument.

38. Original Packaging

39. If original container is to be used, proceed as follows:

a. Place instrument in original container. If it is not available, a suitable container can be purchased from your nearest Hewlett-Packard sales and service office.

b. Be sure the container is well sealed with strong tape or metal band.

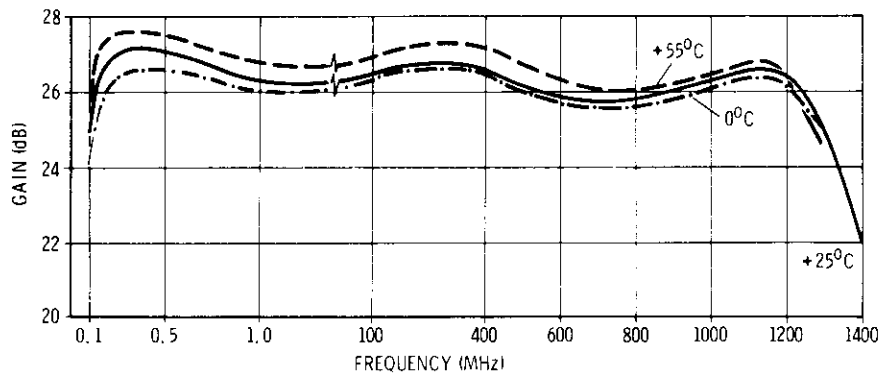

Gain vs. Frequency vs. Temperature

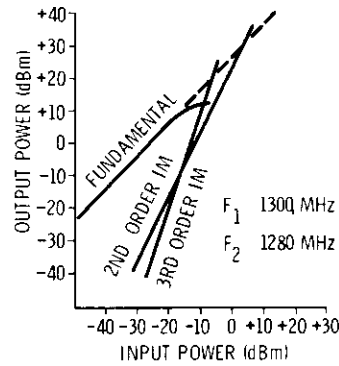
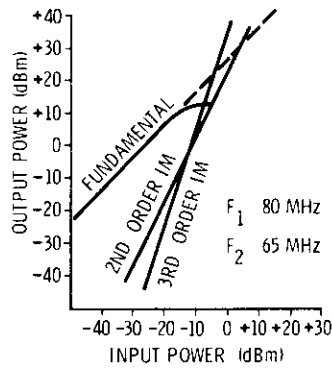

Intermodulation Intercept Points

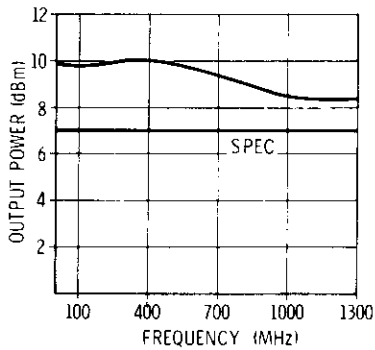

Output Power (1 dB Compression) vs. Frequency

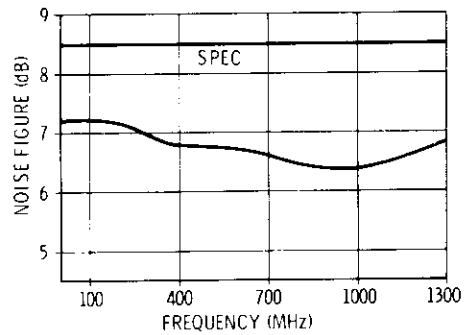

Noise Figure vs. Frequency

Figure 1. Typical Preamplifier Performance Curves

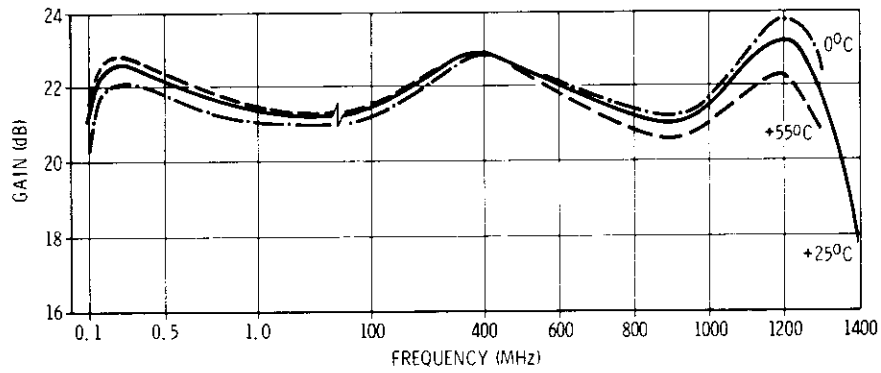

Gain vs. Frequency vs. Temperature

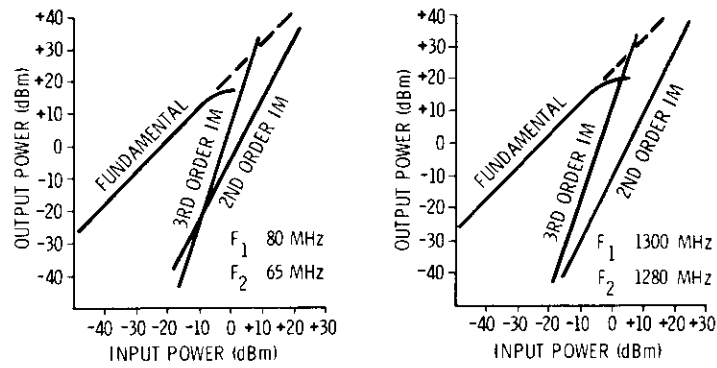

Intermodulation Intercept Points

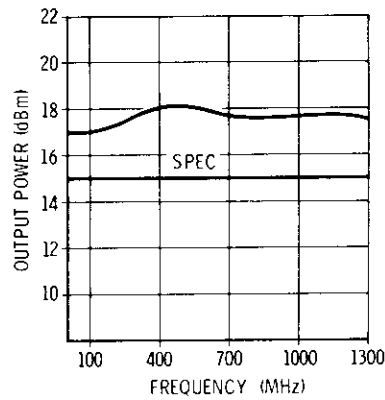

Output Power (1 dB Compression) vs. Frequency

Figure 2. Typical Power Amplifier Performance Curves

Table 2. Recommended Test Equipment and Accessories

Instrument Type	Minimum Specifications	Suggested Model	Use*
Generator/Sweeper	Frequency Range: 0.1 to 110 MHz Flatness: ± 0.25 dB over full range Output Level: +10 dBm minimum Frequency Accuracy: 1% ± 100 KHz Compatible with Network Analyzer	HP 8601A	P,T
Sweep Oscillator	Frequency Range: 0.1 to 1.3 GHz Flatness: 0.7 dB over full range Output Level: +10 dBm minimum Frequency Accuracy: ± 20 MHz Compatible with Network Analyzer	HP 8620A/8621A	P,T
Network Analyzer (0.1–110 MHz)	System (with a swept source) capable of measuring amplitude of reflected signals (return loss). Frequency Range: 0.1 to 1300 MHz Resolution: 0.25 dB Accuracy: $\pm 6\%$	HP 8407A	P
Network Analyzer (0.11–1.3 GHz)		HP 8410A	
Phase-Magnitude Display		HP 8412A	
Harmonic Frequency Converter		HP 8411A	
S-Parameter Test Set		HP 8745A	
Universal Extension		HP 11604A	
Transmission Kit		HP 11651A	
Accessory Kit		HP 11570A	
Spectrum Analyzer RF Section	Frequency Range: 10–1300 MHz Dynamic Range: 60 dB minimum Scan Width: 800 MHz minimum Spurious Responses: < -60 dB Absolute amplitude calibration. Variable persistence display.	HP 8555A	P
Spectrum Analyzer IF Section		HP 8552A	
Display Section		HP 141T	
Noise Figure Meter	Frequency Range: 0.1–1300 MHz Noise Figure Range: 0–15 dB Accuracy: ± 0.5 dB Excess Noise Ratio: 6.3 ± 0.5 dB	HP 342A	P
VHF Noise Source		HP 343A	
UHF Noise Source		HP 349A	

Table 2. Recommended Test Equipment and Accessories (Cont'd)

Instrument Type	Minimum Specifications	Suggested Model	Use*
RMS Voltmeter	Voltage Range: 1 mV to 1 V (full range) Frequency Range: 10 Hz to 10 MHz Meter Accuracy: $\pm 5\%$	HP 3400A	P,A, T
Power Meter	Power Range: -20 dBm to +10 dBm Frequency Range: 10-1300 MHz Meter Accuracy: $\pm 1\%$	HP 432A/478A	P
Amplifier	Gain: 24 dB Noise: < 8 dB Frequency Range: 0.1 - 1300 MHz	HP 8447D	P
Digital Voltmeter	Voltage Range: 0 - 60 V Accuracy: $\pm 0.05\% \pm 1$ digit Resistance Range: 0 to 10 megohm Accuracy: $\pm 0.3\% \pm 1$ digit	HP 3440A/3444A	A,T
Double Balanced Mixers	Frequency Range: 200 - 1300 MHz	Sage Laboratories 2500 Series	P
Low Pass Filter	Cutoff Frequency: 400 MHz Attenuation: >60 dB at 800 and 1200 MHz	Cir-Q-Tel FLT/2 Series	P
Attenuator	10 dB, 0.1 - 1300 MHz	HP 8491A Option 10	P
Attenuator	20 dB, 0.1 - 1300 MHz	HP 8491A Option 20	P
Termination	50 ohm (BNC)	HP 11593A	P
Termination	50 ohm (Type N)	HP 908A	P
Adapter	Type N Female to BNC Male	UG-349A/U	P
Adapter (2)	BNC Female to Type N Male	UG-201A/U	P
Tee	BNC	UG-274B/U	P
Cable Assembly	Type N Connectors	HP 11500A	P
Cable Assembly (5)	BNC Connectors	HP 10503A	P
Cable Assembly	BNC with test clips attached	HP 10501A	A,T
Adapter	BNC Female to Binding Post	HP 10111A	P,A,T
Adapter	BNC Male to BNC Male	UG-491A/U	P
*Use: P = Performance Test; A = Adjustments; T = Troubleshooting			

40. Other Packing Material

41. If original container is not used, proceed as follows:

a. Wrap instrument in heavy paper or plastic before placing in inner container.

b. Place packing material around all sides of the instrument and protect panel face with cardboard strips.

c. Place instrument in a heavy carton or wooden box and seal with strong tape or metal band. A double-wall carton made of 200 pound test material is adequate.

d. Mark shipping container; *Delicate Instrument. Fragile, etc.*

42. OPERATING INSTRUCTIONS

43. Connect the line power cable to the three-prong rear panel socket and proceed as follows:

a. Select the line power to be used (115 or 230 volts) with the rear panel SELECTOR switch.

b. Connect the line power cable to line power.

c. Push LINE switch ON.

CAUTION

Do not apply power levels to the amplifier that are higher than the following:

8447D: 0 dBm

8447E: +10 dBm

8447F PREAMP: 0 dBm

8447F POWER AMP: +10 dBm

d. Attach INPUT and OUTPUT cables

CAUTION

Power out of the 8447E and power out of the 8447F POWER AMP can exceed 100 mW. This may be enough power to damage sensitive circuits connected to OUTPUT.

44. OPERATOR MAINTENANCE

45. Operator maintenance is limited to replacement of the front panel LINE switch light, the A1 Power Supply fuse, and the rear panel fuse.

46. Fuses

47. To replace the rear panel fuse (F1), remove the rear panel fuse knob and replace the fuse (see rear panel for value of F1).

48. To replace the A1 Power Supply (A1F1) fuse, turn the instrument on its top. Lift tilt stand and remove the bottom cover. Replace the fuse on the A1 Power Supply board (see parts list for value of A1F1).

49. Lamp Replacement

50. To replace the front panel line switch lamp (DS1), proceed as follows:

a. Disconnect cord from rear panel receptacle.

b. Pull the white cover portion of this switch from the instrument and then remove the lamp from inside the cover.

c. Replace old lamp with a new lamp (see parts list for part number of DS1).

d. Place white cover into switch receptacle.

e. Align tab on white cover with socket and push in.

51. PERFORMANCE TESTS AND ADJUSTMENT PROCEDURE

52. Test equipment and accessories required to perform maintenance are listed in Table 2. Equipment other than recommended models can be used provided the minimum specifications are satisfied.

53. The performance tests assume the use of a standard amplifier with BNC connectors. If an amplifier with Type N connectors is to be tested, suitable adapters will have to be added to the equipment lists.

54. One series of performance tests and one adjustment procedure covers all three amplifiers. Where required, test steps list equipment settings, etc., for each amplifier. If a test step lists only one setting or specification, it is valid for all three amplifiers. Disregard references to any amplifier not being tested.

PERFORMANCE TESTS

55. Gain Flatness, Mean Gain, and Gain Compression

Specifications

	8447D	8447E	8447F	
	PREAMP	POWER AMP	PRE AMP	POWER AMP
Gain Flatness Across Full Frequency Range	±1.5 dB	±1.5 dB	±1.5 dB	±1.5 dB
Mean Gain (20°C – 30°C)	25 dB Minimum	22 dB ±1.5 dB	25 dB Minimum	22 dB ±1.5 dB
Output Power for 1 dB Gain Compression		+14 dBm		+14 dBm

Description:

Amplifier gain is measured at the maximum and minimum points of its frequency response (see Figures 1 and 2). The difference between highest measured gain and lowest measured gain should be less than 3 dB (gain flatness). Half of the sum of highest gain and lowest gain is measured mean gain and should be within 1 dB of specified gain. Compression is checked by measuring gain at the specified 1 dB compression point and comparing it to gain measured below compression.

Equipment:

- Generator/Sweeper HP 8601 A
- Sweep Oscillator HP 8620A/8621 A
- RMS Voltmeter HP 3400A
- Power Meter HP 432A/478A
- BNC Cable Assembly (2) HP 10503A
- BNC Tee UG-274B/U
- 50 ohm Termination HP 11593A
- Adapter UG-349A/U
- Adapter UG-201A/U
- Adapter HP 1250-0080
- 20 dB Attenuator HP 8491B-20
- 10 dB Attenuator HP 8491B-10

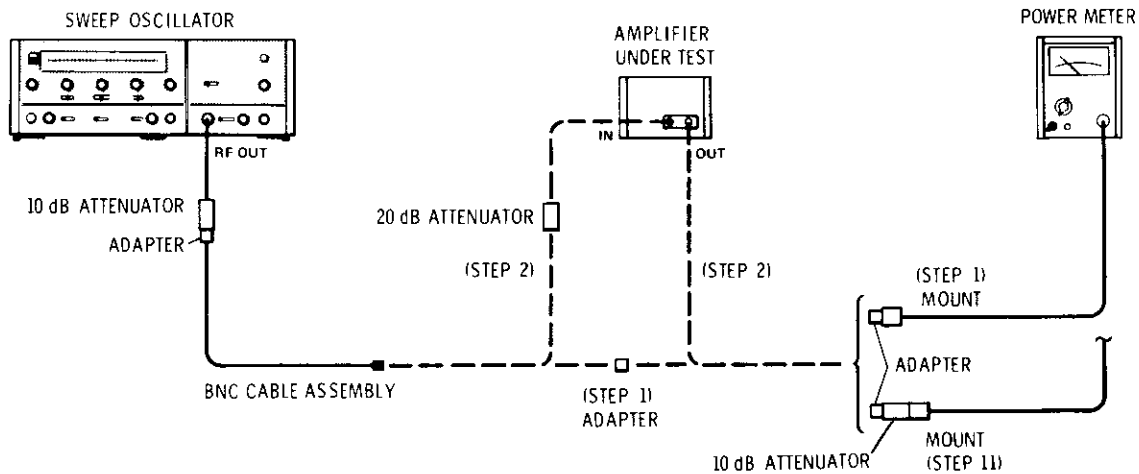

Figure 3. Gain Flatness, Mean Gain, and Gain Compression Test Setup: 10 MHz to 1.3 GHz

PERFORMANCE TESTS

55. Gain Flatness, Mean Gain, and Gain Compression (Cont.)*Procedure:*

1. To measure gain flatness and mean gain, connect the equipment as shown in Figure 3. Set the sweep oscillator for a 1.3 GHz, leveled, CW signal; set the signal level for -10 dBm out of the 10 dB attenuator (read on the power meter).
2. Disconnect the power meter from the sweep oscillator and 10 dB attenuator. Connect the sweep oscillator, through the 10 dB and 20 dB attenuators, to amplifier INPUT; connect the power meter to amplifier OUTPUT. Note the power meter reading. Use this reading to calculate amplifier gain.

EXAMPLE:

-7 dBm (read in step 2) minus -10 dBm (set in step 1) plus 20 dB (read from attenuator) = 23 dB (gain)

Gain at 1300 MHz: _____ dB

NOTE

Use attenuation printed on 20 dB attenuator; this may vary slightly, depending upon frequency.

3. Tune the sweep oscillator for a maximum indication on the power meter at 1150 ± 100 MHz. Disconnect the oscillator and the power meter from the amplifier. Connect the power meter, through the 10 dB attenuator, to the oscillator. Set the oscillator signal level for -10 dBm out of the attenuator.
4. Disconnect the power meter from the sweep oscillator and 10 dB attenuator. Connect the oscillator, through the 10 dB and 20 dB attenuators, to amplifier INPUT; connect the power meter to amplifier OUTPUT. Calculate and record amplifier gain (as performed in step 2).

Gain at 1150 MHz: _____ dB

5. Measure, calculate and record amplifier gain at the following frequencies; use the procedures outline in steps 3 and 4.

Frequency	Gain
800 \pm 200 MHz (tune for minimum):	_____ dB
350 \pm 100 MHz (tune for maximum):	_____ dB

6. Disconnect the sweep oscillator and the power meter from the amplifier. Connect the equipment as shown in Figure 4. Set the generator/sweeper for a 10 MHz, CW signal; set the signal level for -40 dB (read on the voltmeter).
7. Disconnect the voltmeter from the generator/sweeper. Connect the generator/sweeper to amplifier INPUT; connect the voltmeter, with the 50 ohm termination, to amplifier OUTPUT. Note the voltmeter reading. Use this reading to calculate amplifier gain.

EXAMPLE:

-18.5 dB (read in step 7) minus -40 dB (set in step 6) = 21.5 dB (gain)

Gain at 10 MHz: _____ dB

PERFORMANCE TESTS

55. Gain Flatness, Mean Gain, and Gain Compression (Cont.)

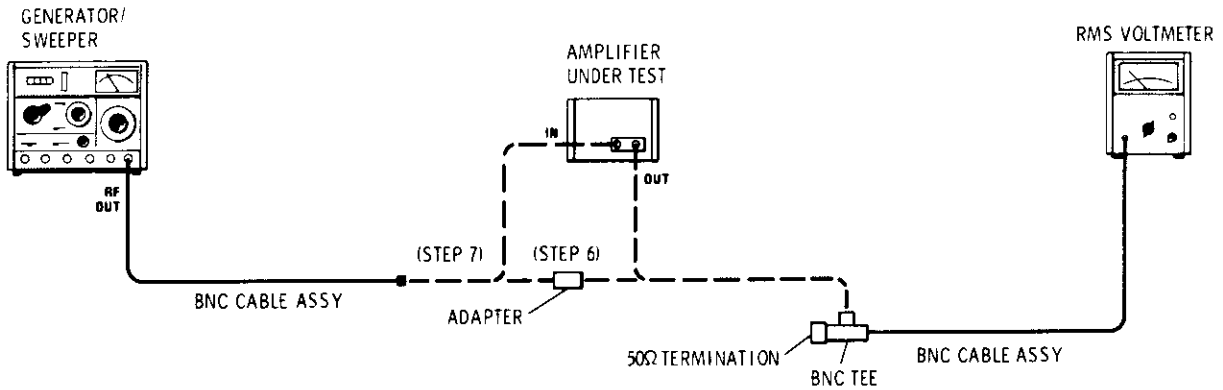

Figure 4. Flatness and Mean Gain Test Setup: 100 kHz to 10 MHz

8. Measure, calculate and record amplifier gain at the following frequencies; use the procedures outlined above.

Frequency	Gain
250 ±100 kHz (tune for maximum):	_____ dB
100 kHz:	_____ dB

9. Select the highest and lowest gains from steps 2, 4, 5, 7, and 8. Subtract the lowest gain from the highest gain; the result is gain flatness and should be less than 3 dB.

EXAMPLE:

23 dB (highest gain) minus 21.5 dB (lowest gain) = 1.5 dB (gain flatness)

Gain Flatness: _____ 3 dB

10. Add the highest and lowest gains together and divide by 2; the result is measured mean gain.

EXAMPLE:

$\frac{23 \text{ dB (highest gain) plus } 21.5 \text{ dB (lowest gain)}}{2} = 22.25 \text{ dB (mean gain)}$

	Min.	Actual	Max.
Mean Gain, 8447D:	25	23 dB	_____
8447E:	20	20.5 dB	20.5 dB 24
8447F PRE AMP:	25	23 dB	_____
8447F POWER AMP:	20	20.5 dB	20.5 dB 24

NOTE

Gain rolls off rapidly above 1300 MHz and below 0.1 MHz. If lowest gain was measured at either of these points, use a frequency counter to monitor the signal and repeat steps 1 through 10.

PERFORMANCE TESTS

55. Gain Flatness, Mean Gain, and Gain Compression (Cont.)

11. To check compression, connect the power meter mount, through the 10 dB attenuator, to amplifier OUTPUT (as shown in Figure 3). Connect the sweep oscillator, through the 20 dB attenuator, to amplifier INPUT. Set the sweep oscillator for a leveled, 650 MHz, CW signal and set the signal level (read on the power meter) as follows:

8447E: $+4$ dBm (+1~~4~~ dBm ampl. output)

8447F POWER AMP: $+4$ dBm (+1~~4~~ dBm ampl. output)

12. Without changing any of the sweep oscillator's settings, move the 10 dB attenuator from amplifier OUTPUT to amplifier INPUT; the power meter should now be connected directly to amplifier OUTPUT and the sweep oscillator should be connected through the 20 dB attenuator and the 10 dB attenuator to amplifier INPUT.

13. The power meter should read as follows:

8447E less than $+5$ dBm: _____ $+5$ dBm

8447F POWER AMP less than $+5$ dBm: _____ $+5$ dBm

14. Repeat steps 11 through 13 at various frequencies between 0.1 and 1300 MHz.

56. VSWR

Specification (1 to 1300 MHz):

8447D PRE AMP	8447E POWER AMP	8447F	
		PRE AMP	POWER AMP
< 2.0 INPUT < 2.2 OUTPUT	< 2.2	< 2.0 INPUT < 2.2 OUTPUT	< 2.2

Description:

A network analyzer is swept, in steps, from 1 to 1300 MHz. At each step the analyzer's display is referenced to 0 dB return loss by shorting its output; the short is then removed and the amplifier's return loss is measured at INPUT and OUTPUT.

Equipment:

- Sweep Oscillator HP 8620A/8621 A
- Generator/Sweeper HP 8601 A
- Network Analyzer (0.1 to 110 MHz) HP 8407A
- Network Analyzer (0.11 to 1.3 GHz) HP 8410A

PERFORMANCE TESTS

56. VSWR (Cont.)

Equipment (Cont.):

Phase-Magnitude Display	HP 8412A
Harmonic Frequency Converter	HP 8411A
S-Parameter Test Set	HP 8745A
Universal Extension	HP 11604A
Transmission Kit	HP 11651A
Accessory Kit	HP 11570A
Cable Assembly (3)	HP 10503A
Cable Assembly	HP 11500A

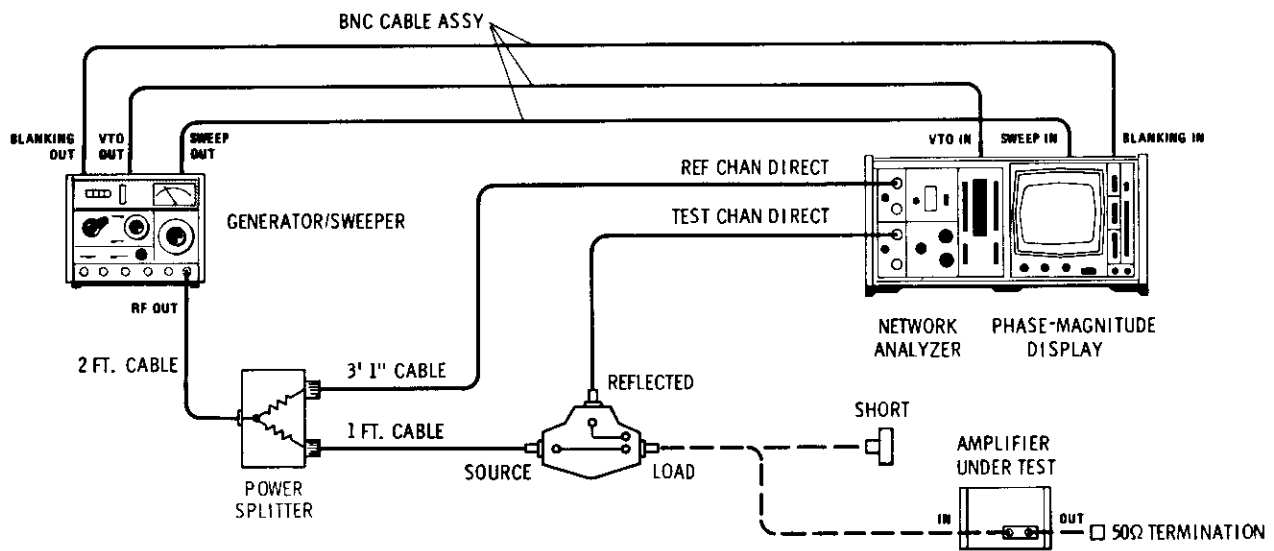

Figure 5. VSWR Test Setup: 1 to 110 MHz

Procedure:

1. Connect the equipment as shown in Figure 5. Set the generator/sweeper for a -10 dBm signal, sweeping from 1 to 110 MHz.
2. Connect the short to the directional bridge and calibrate the network analyzer for a 0 dB return loss reference on the display (use the center horizontal graticule line).
3. Remove the short from the directional coupler, attach the coupler to amplifier INPUT (terminate OUTPUT with 50 ohms).
4. Decrease the display reference level to -10 dB (the center horizontal graticule line now represents a return loss of 10 dB). The measured return loss should be as shown below:

INPUT VSWR, 1 to 110 MHz:

8447D, >9.6 dB: 9.6 dB _____	8447F PRE AMP, >9.6 dB: 9.6 dB _____
8447E, >8.8 dB: 8.8 dB _____	8447F POWER AMP, >8.8 dB: 8.8 dB _____

PERFORMANCE TESTS

56. VSWR (Cont.)

5. Measure return loss at amplifier OUTPUT (terminate INPUT with 50 ohms). The measured return loss should be greater than 8.8 dB.

OUTPUT VSWR, 1 to 110 MHz: 8.8 dB _____

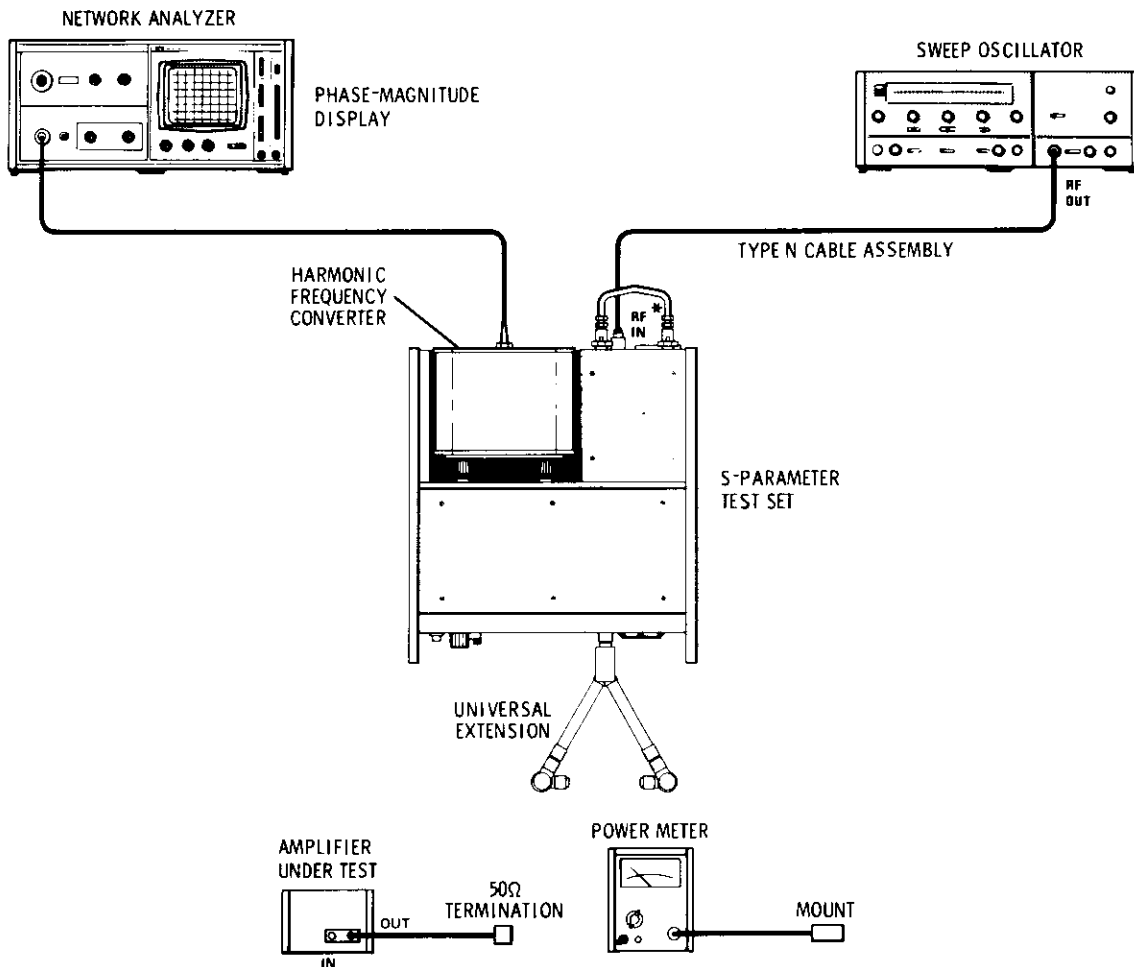

Figure 6. VSWR Test Setup: 0.11 to 1.3 GHz

6. Connect the equipment as shown in Figure 6. Set the sweep oscillator for a leveled CW signal, sweeping from 110 to 220 MHz. Connect the power meter to s-parameter test set INPUT PORT A and set the generator/sweeper's output level for -15 dBm as read on the power meter.
7. Disconnect the power meter from the test set and connect a short to INPUT PORT A (measuring S_{11} at INPUT PORT A). Calibrate the analyzer for a 0 dB return loss reference on the display (use the center horizontal graticule line). Note TEST CHANNEL GAIN at the reference:

Reference TEST CHAN. GAIN, 110 to 220 MHz: _____ dB

8. Disconnect the short from INPUT PORT A. Terminate amplifier OUTPUT with 50 ohms. Connect INPUT PORT A to amplifier INPUT.
-

PERFORMANCE TESTS

56. VSWR (Cont.)

9. Set TEST CHANNEL GAIN 10 dB above the reference in step 7. The center horizontal graticule line now represents a return loss of 10 dB. The measured return loss should be as shown below:

INPUT VSWR, 110 to 220 MHz:

8447D, >9.6 dB: 9.6 dB _____ 8447F PRE AMP, >9.6 dB: 9.6 dB _____
 8447E, >8.8 dB: 8.8 dB _____ 8447F POWER AMP, >8.8 dB: 8.8 dB _____

10. Repeat steps 8 and 9, measuring return loss at amplifier OUTPUT (terminate amplifier INPUT with 50 ohms). The measured return loss should be greater than 8.8 dB:

OUTPUT VSWR, 110 to 220 MHz: 8.8 dB _____

11. Set the sweep oscillator to sweep each of the ranges shown below, repeating steps 7 through 10 for each range.

Sweep Range	Reference: TEST CHAN. GAIN	8447D INPUT, 8447F PRE AMP INPUT	8447E INPUT, 8447F POWER AMP INPUT	OUTPUT
220 to 440 MHz	_____ dB	9.6 dB _____	8.8 dB _____	8.8 dB _____
440 to 880 MHz	_____ dB	9.6 dB _____	8.8 dB _____	8.8 dB _____
880 to 1300 MHz	_____ dB	9.6 dB _____	8.8 dB _____	8.8 dB _____

57. Distortion and Reverse Isolation

Specifications:

	8447D PRE AMP	8447E POWER AMP	8447F	
			PRE AMP	POWER AMP
Harmonic Distortion	/	-30 dB for +10 dBm output	/	-30 dB for +10 dBm output
Reverse Isolation	>40 dB	> 40 dB	> 40 dB	> 40 dB

Description:

A fixed, CW signal at 400 MHz is filtered and applied to amplifier INPUT. Amplifier OUTPUT is connected to a spectrum analyzer, and the analyzer is used to check the second and third harmonic levels. Reverse isolation is checked by applying a known signal level to amplifier OUTPUT and measuring it at amplifier INPUT.

PERFORMANCE TESTS

58. Noise Figure (Cont.)

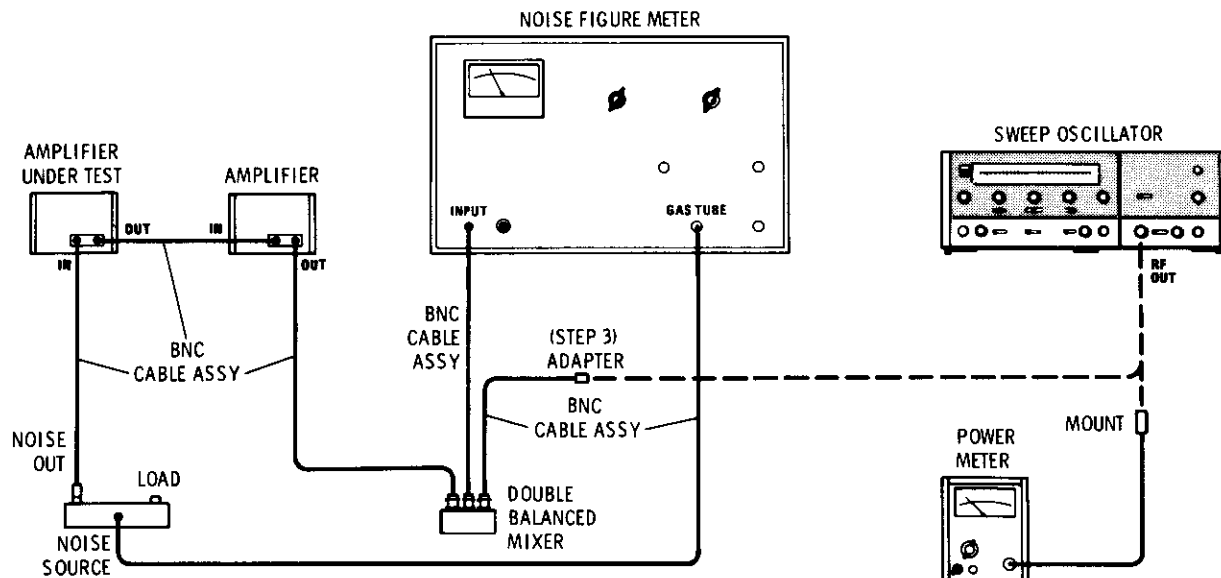

Figure 9. Noise Figure Test Setup: 1200 MHz

Procedure:

1. Connect the equipment as shown in Figure 8. Calibrate the noise figure meter. Check the amplifier's noise figure at 100 MHz (or 105 MHz); it should be less than 8.5 dB:

100 MHz: _____ 8.5 dB

2. Connect the equipment as shown in Figure 9. Set the sweep oscillator for a fixed, CW signal at 1300 MHz; set the signal level out of the oscillator for +10 dBm read on the power meter.
3. Disconnect the power meter from the oscillator and connect the oscillator to the mixer.
4. Set the noise figure meter to measure noise at 100 MHz; calibrate the meter.

NOTE

If the noise figure meter being used has a 105 MHz input frequency, set the sweep oscillator (in step 2) to 1305 MHz.

5. Check the amplifier's noise figure; it should be less than 8.5 dB:

1200 MHz: _____ 8.5 dB

ADJUSTMENT

59. Power Supply Voltage Check and Adjustment

Description:

To insure that the amplifier gives proper gain, the power supply is adjusted to 20 volts ±0.1 volt.

Equipment:

Digital Voltmeter	HP 3440A/3444A
RMS Voltmeter	HP 3400A
Cable Assembly (w/test clips)	HP 10501A
Adapter	HP 10111A

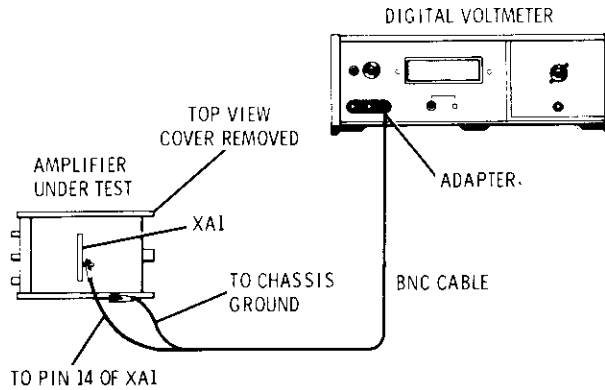

Figure 10. Power Supply Voltage Adjustment Test Setup

Procedure:

1. Connect the test setup in Figure 10. Set the digital voltmeter to measure +20 volts dc.
2. Adjust A1R9 VOLT ADJ for a digital voltmeter reading of +20 V ±0.1 Vdc

DVM: +9.9 _____ +20.1 Vdc

3. Remove the digital voltmeter from the amplifier and connect the RMS voltmeter to XA1 pin 14. The ripple voltage should be as shown below.

8447D <0.35 mVrms: _____ 0.35 mVrms

8447E <0.50 mVrms: _____ 0.50 mVrms

8447F <0.50 mVrms: _____ 0.50 mVrms

60. REPLACEABLE PARTS

61. Tables 4, 5 and 6 list parts in alpha-numerical order of their reference designations. It is important that you refer to the table that documents the instrument being serviced. Cabinet parts for all three amplifiers are listed in Figure 11. Figure 12 lists the parts that make up the Type N connector used in amplifier options 010 and 011.

62. ORDERING INFORMATION

63. To obtain replacement parts, address order or inquiry to your local Hewlett-Packard field office

(see list at rear of this manual for address). Identify parts by their Hewlett-Packard part numbers.

64. To obtain a part that is not listed, include:

- a. Instrument model number.
- b. Instrument serial number
- c. Description of the part.
- d. Function and location of the part.

Table 3. Reference Designations and Abbreviations

REFERENCE DESIGNATORS			
A = assembly	F = fuse	P = plug	V = vacuum tube, neon bulb, photocell, etc.
B = motor	FL = Filter	Q = transistor	VR = voltage regulator
BT = battery	J = jack	R = resistor	W = cable
C = capacitor	K = relay	RT = thermistor	X = socket
CP = coupler	L = inductor	S = switch	Y = crystal
CR = diode	LS = loud speaker	T = transformer	Z = tuned cavity, network
DL = delay line	M = meter	TB = terminal board	
DS = device signaling (lamp)	MK = microphone	TP = test point	
E = misc electronic part	MP = mechanical part	U = integrated circuit	
ABBREVIATIONS			
A = amperes	H = henries	N/O = normally open	RMO = rack mount only
AFC = automatic frequency control	HDW = hardware	NOM = nominal	RMS = root-mean square
AMPL = amplifier	HEX = hexagonal	NPO = negative positive zero (zero temperature coefficient)	RWV = reverse working voltage
BFO = beat frequency oscillator	HG = mercury		S-B = slow-blow
BE CU = beryllium copper	HR = hour(s)	NPN = negative-positive-negative	SCR = screw
BH = binder head	Hz = Hertz		SE = selenium
BP = bandpass	IF = intermediate freq	NRFR = not recommended for field replacement	SECT = section(s)
BRS = brass	IMPG = impregnated	NSR = not separately replaceable	SEMICON = semiconductor
BWO = backward wave oscillator	INCD = incandescent		SI = silicon
	INCL = include(s)	OBD = order by description	SIL = silver
	INS = insulation(ed)	OH = oval head	SL = slide
	INT = internal	OX = oxide	SPG = spring
			SPL = special
CCW = counterclockwise	K = kilo = 1000	P = peak	SST = Stainless steel
CER = ceramic		PC = printed circuit	SR = split ring
CMO = cabinet mount only	LH = left hand	PF = picofarads = 10 ⁻¹² farads	STL = steel
COEF = coefficient	LIN = linear taper	PH BRZ = phosphor bronze	TA = tantalum
COM = common	LK WASH = lock washer	PHL = Phillips	TD = time delay
COMP = composition	LOG = logarithmic taper	PIV = peak inverse voltage	TGL = toggle
COMPL = complete	LPF = low pass filter	PNP = positive-negative-positive	THD = thread
CONN = connector		P/O = part of	TI = titanium
CP = cadmium plate	M = milli = 10 ⁻³	POLY = polystyrene	TOL = tolerance
CRT = cathode-ray tube	MEG = meg = 10 ⁶	PORC = porcelain	TRIM = trimmer
CW = clockwise	MET FLM = metal film	POS = position(s)	TWT = traveling wave tube
DEPC = deposited carbon	MET OX = metallic oxide	POT = potentiometer	
DR = drive	MFR = manufacturer	PP = peak-to-peak	
ELECT = electrolytic	MHz = mega Hertz	PT = point	
ENCAP = encapsulated	MINAT = miniature	PWV = peak working voltage	
EXT = external	MOM = momentary	RECT = rectifier	
	MOS = metalized substrate	RF = radio frequency	
F = farads	MTG = mounting	RH = round head or right hand	
FH = flat head	MY = "mylar"		
FIL H = Fillister head			
FXD = fixed	N = nano (10 ⁻⁹)		
	N/C = normally closed		
G = giga (10 ⁹)	NE = neon		
GE = germanium	NI PL = nickel plate		
GL = glass			
GRD = ground(ed)			

Table 4. 8447D Replaceable Parts

Reference Designation	HP Part Number	C D	Qty	Description	Mfr Code	Mfr Part Number
A1	08447-60011	0	1	BOARD ASSY: POWER SUPPLY	28480	08447-60011
A1C1	0150-0024	7	13	C:FXD CER 0.02 UF +80-20% 600 VDCW	71590	TYPE DD 203
A1C2	0180-0228	6	1	C:FXD ELECT 22 UF 10% 15VDCW	56289	150D226X9015B2-DYS
A2C3	0160-0162	5	1	C:FXD MY 0.022 UF 10% 200VDCW	56289	192P22392-PT5
A2C4	0180-0116	1	1	C:FXD ELECT 6.8 UF 10% 35VDCW	56289	150D685X9035B2-DYS
A1C5	0180-1819	3	1	C:FXD ELECT 100 UF +75-10% 50VDCW	28480	0180-1819
A1CR1	1901-0159	3	4	DIODE:SILICON 0.75A 400PIV	02037	SR1358-4
A1CR2	1901-0159	3		DIODE:SILICON 0.75A 400PIV	02037	SR1358-4
A1CR3	1901-0159	3		DIODE:SILICON 0.75A 400PIV	02037	SR1358-4
A1CR4	1901-0159	3		DIODE:SILICON 0.75A 400PIV	02037	SR1358-4
A1CR5	1902-3036	3	1	DIODE:BREAKDOWN 3.16V 5%	02037	SZ10939-38
A1CR6	1902-0761	5	1	DIODE:BREAKDOWN 5.9 to 6.5V	12954	1N821
A1CR7	1901-0025	2	2	DIODE:SILICON 100MA/1V	07263	FD 2387
A1CR8	1902-3268	3	1	DIODE:BREAKDOWN:26.1V 5%	28480	1902-3268
A1CR9	1884-0073	2	1	THYRISTER:SCR TO-5 VRRM=100	01921	SCR1400
A1CR10	1901-0025	2		DIODE:SILICON 100MA/1V	07263	FD 2387
A1F1	2110-0012	0	2	FUSE:0.5 AMP 250V	04703	312,500
A1F1	2110-0269	9	1	CLIP:FUSE 0.250" DIA	91506	6008-32CN
A1Q1	1853-0012	4	1	TSTR:SI PNP	80131	2N2904A
A1Q2	1854-0022	8	1	TSTR:SI NPN	07263	S17843
A1Q3	1854-0071	7	3	TSTR:SI NPN (SELECTED FROM 2N3704)	28480	1854-0071
A1Q4	1854-0071	7		TSTR:SI NPN (SELECTED FROM 2N3704)	28480	1854-0071
A1Q5	1854-0071	7		TSTR:SI NPN (SELECTED FROM 2N3704)	28480	1854-0071
A1R1	0757-0836	5	2	R:FXD MET FLM 7.50K OHM 1% 1/2W	28480	0757-0836
A1R2	0757-0278	9	1	R:FXD MET FLM 1.78K OHM 1% 1/8W	28480	0757-0278
A1R3	0757-0836	5		R:FXD MET FLM 7.50K OHM 1% 1/2W	28480	0757-0836
A1R4	0811-1668	9	1	R:FXD WW 1.5 OHM 5% 2W	28480	0811-1668
A1R5	0698-0089	4	1	R:FXD MET FLM 1.78K OHM 1% 1/2W	28480	0698-0089
A1R6	0698-0083	8	1	R:FXD MET FLM 1.96K OHM 1% 1/8W	28480	0698-0083
A1R7	0698-3440	7	1	R:FXD MET FLM 196 OHM 1% 1/8W	28480	0698-3440
A1R8	0757-0416	7	1	R:FXD MET FLM 511 OHM 1% 1/8W	28480	0757-0416
A1R9	2100-1758	3	1	R:VAR WW 1K OHM 5% TYPE V 1W	28480	2100-1758
A1R10	0698-3154	0	1	R:FXD MET FLM 4.22K OHM 1% 1/8W	28480	0698-3154
A1R11	0757-1094	9	1	R:FXD MET FLM 1.47K OHM 1% 1/8W	28480	0757-1094
A1R12	0698-3442	9	1	R:FXD MET FLM 237 OHM 1% 1/8W	28480	0698-3442
A1R13	0757-0180	2	1	R:FXD MET FLM 31.6 OHM 1% 1/8W	28480	0757-0180
A1R14	0757-0401	0	1	R:FXD MET FLM 100 OHM 1% 1/8W	28480	0757-0401
A1TB1	08447-20011	6	1	BOARD:BLANK PC	28480	84447-20011
C1	0180-2272	4	1	C:FXD ELECT 850 UF +50-10% 75VDCW	56289	36D851F075AA2A DQB
C2	0160-2049	1	1	C:FXD CER FEED-THRU 5000 PF +80-20%	28480	0160-2049
C3	0180-0291	3	1	C:FXD ELECT 1.0 UF 10% 35VDCW	56289	150D105X9035A2-DYS
DS1	2140-0244	4	1	LAMP:GLOW MINIATURE 95V	87034	A1H
F1	2110-0012	1		FUSE:0.5 AMP 250V	04703	312,500
J1	1251-2357	8	1	SOCKET:3-PIN MALE POWER (P/O REAR PANEL)	82389	EAC-301
J2				PART OF W2		
J3				PART OF W3		
J4				PART OF W4		
J5				PART OF W5		
L1	9100-1618	1	2	COIL:MOLDED CHOKE 5.60 UH	28480	9100-1618
L2	9100-1618	1		COIL:MOLDED CHOKE 5.60 UH (OPT'S 001 AND 011 ONLY)	28480	9100-1618
MP1	08447-00005	6	1	INSULATOR:TOP COVER	28480	08447-00005
MP2	08447-00028	3	1	SUPPORT:AMPLIFIER (OPT'S 001 AND 011 ONLY)	28480	08447-00028
Q1	1854-0063	7	1	TSTR:SI NPN	80131	2N3055
R1	0683-2735	0	1	R:FXD COMP 27K OHM 5% 1/4W	01121	CB 2735
S1	3101-2195	7	1	SWITCH-PB DPST-NO ALTN 10.5A 250VAC	04757	53-67600-123
S1	0590-0012	5	2	NUT:KNURLED 15/32-32	04009	899U-3
S2	3101-1234	3	1	SWITCH:SLIDE DPDT	82389	11A-1242
T1	9100-2894	7	1	TRANSFORMER:POWER	28480	9100-2894
U1, U2	0960-2013	5		HYBRID MC:PRE-AMPL 0.1-1300 MHZ (OPT'S 001 AND 011 ONLY)	28480	0960-2013
U1, U2						
W1	8120-1348	5	1	CABLE ASSY:POWER, DETACHABLE	70903	KHS-7041
W2	08447-20002	5	1	CABLE ASSY:TYPE N INPUT (OPT'S 010 AND 011)	28480	08447-20002
W2	08447-20006	9	1	CABLE ASSY:BNC INPUT	28480	08447-20006
W3	08447-20003	6	1	CABLE ASSY:TYPE N OUTPUT (OPT'S 010 AND 011)	28480	08447-20003
W3	08447-20007	0	1	CABLE ASSY:BNC OUTPUT	28480	08447-20007
W4	08447-20004	7	1	CABLE ASSY:TYPE N INPUT (OPT 011)	28480	08447-20004
W4	08447-20008	1	1	CABLE ASSY:BNC INPUT (OPT 001)	28480	08447-20008
W5	08447-20005	8	1	CABLE ASSY:TYPE N OUTPUT (OPT 011)	28480	08447-20005
W5	08447-20009	2	1	CABLE ASSY:BNC OUTPUT (OPT 001)	28480	08447-20009
W6	08447-20014	9	1	CABLE ASSY:JUMPER (OPT 011 ONLY)	28480	08447-20014
XF1				FUSEHOLDER (INCLUDES THE FOLLOWING PARTS)		
XF1MP1	2110-0564	8	1	FUSEHOLDER BODY 12A MAX FOR UL	28480	2110-0564
XF1MP2	2110-0565	9	1	FUSEHOLDER CAP 12A MAX FOR UL	28480	2110-0565
XF1MP3	2110-0569	3	1	NUT-FUSEHOLDER THREAD	28480	2110-0569
XQ1	1200-0043	8	1	INSULATOR:TSTR MOUNTING (TO-3)	71785	293011
	2190-0037	9	1	WASHER:LOCK SST FOR 1/2 THREAD	78189	1224-08
	0360-0368	7	1	TERMINATION:SOLDER STUD	78189	2168-12-01
	0900-0016	8	1	"O" RING 0.688" OD	00000	OBD

Table 5. 8447E Replaceable Parts

Reference Designation	HP Part Number	C D	Qty	Description	Mfr Code	Mfr Part Number
A1	08447-60011	0	1	BOARD ASSY: POWER SUPPLY	28480	08447-60011
A1C1	0150-0024	7	13	C:FXD CER 0.02 UF +80-20% 600 VDCW	71590	TYPE DD 203
A1C2	0180-0228	6	1	C:FXD ELECT 22 UF 10% 15VDCW	56289	150D226X9015B2-DYS
A2C3	0160-0162	5	1	C:FXD MY 0.022 UF 10% 200VDCW	56289	192P22392-PTS
A2C4	0180-0116	1	1	C:FXD ELECT 6.8 UF 10% 35VDCW	56289	150D685X9035B2-DYS
A1C5	0180-1819	3	1	C:FXD ELECT 100 UF +75-10% 50VDCW	28480	0180-1819
A1CR1	1901-0159	3	4	DIODE:SILICON 0.75A 400PIV	02037	SR1358-4
A1CR2	1901-0159	3		DIODE:SILICON 0.75A 400PIV	02037	SR1358-4
A1CR3	1901-0159	3		DIODE:SILICON 0.75A 400PIV	02037	SR1358-4
A1CR4	1901-0159	3		DIODE:SILICON 0.75A 400PIV	02037	SR1358-4
A1CR5	1902-3036	3	1	DIODE: BREAKDOWN 3.16V 5%	02037	SZ10939-38
A1CR6	1902-0761	5	1	DIODE: BREAKDOWN 5.9 to 6.5V	12954	IN821
A1CR7	1901-0025	2	2	DIODE: SILICON 100MA/1V	07263	FD 2387
A1CR8	1902-3268	3	1	DIODE: BREAKDOWN: 26.1V 5%	28480	1902-3268
A1CR9	1884-0073	2	1	THYRISTER-SCR TO-5 VRRM=100	01921	SCR1400
A1CR10	1901-0025	2		DIODE: SILICON 100MA/1V	07263	FD 2387
A1F1	2110-0012	0	2	FUSE: 0.5 AMP 250V	04703	312.500
A1F1	2110-0269	9	1	CLIP: FUSE 0.250" DIA	91506	6008-32CN
A1Q1	1853-0012	4	1	TSTR: SI NPN	80131	2N2904A
A1Q2	1854-0022	8	1	TSTR: SI NPN	07263	S17843
A1Q3	1854-0071	7	3	TSTR: SI NPN (SELECTED FROM 2N3704)	28480	1854-0071
A1Q4	1854-0071	7		TSTR: SI NPN (SELECTED FROM 2N3704)	28480	1854-0071
A1Q5	1854-0071	7		TSTR: SI NPN (SELECTED FROM 2N3704)	28480	1854-0071
A1R1	0757-0836	5	2	R:FXD MET FLM 7.50K OHM 1% 1/2W	28480	0757-0836
A1R2	0757-0278	9	1	R:FXD MET FLM 1.78K OHM 1% 1/8W	28480	0757-0278
A1R3	0757-0836	5		R:FXD MET FLM 7.50K OHM 1% 1/2W	28480	0757-0836
A1R4	0811-1668	9	1	R:FXD WW 1.5 OHM 5% 2W	28480	0811-1668
A1R5	0698-0089	4	1	R:FXD MET FLM 1780 OHM 1% 1/2W	28480	0698-0089
A1R6	0698-0083	8	1	R:FXD MET FLM 1.96K OHM 1% 1/8W	28480	0698-0083
A1R7	0698-3440	7	1	R:FXD MET FLM 196 OHM 1% 1/8W	28480	0698-3440
A1R8	0757-0416	7	1	R:FXD MET FLM 511 OHM 1% 1/8W	28480	0757-0416
A1R9	2100-1758	3	1	R:VAR WW 1K OHM 5% TYPE V 1W	28480	2100-1758
A1R10	0698-3154	0	1	R:FXD MET FLM 4.22K OHM 1% 1/8W	28480	0698-3154
A1R11	0757-1094	9	1	R:FXD MET FLM 1.47K OHM 1% 1/8W	28480	0757-1094
A1R12	0698-3442	9	1	R:FXD MET FLM 237 OHM 1% 1/8W	28480	0698-3442
A1R13	0757-0180	2	1	R:FXD MET FLM 31.6 OHM 1% 1/8W	28480	0757-0180
A1R14	0757-0401	0	1	R:FXD MET FLM 100 OHM 1% 1/8W	28480	0757-0401
A1TB1	08447-20011	6	1	BOARD: BLANK PC	28480	08447-20011
C1	0180-2272	4	1	C:FXD ELECT 850 UF +50-10% 75VDCW	56289	36D851F075AA2A DQB
C2	0160-2049	1	1	C:FXD CER FEED-THRU 5000 PF +80-20%	28480	0160-2049
C3	0180-0291	3	1	C:FXD ELECT 1.0 UF 10% 35VDCW	56289	150D105X9035A2-DYS
DS1	2140-0244	4	1	LAMP: GLOW MINIATURE 95V	87034	A1H
F1	2110-0012	1		FUSE: 0.5 AMP 250V	04703	312.500
J1	1251-2357	8	1	SOCKET: 3-PIN MALE POWER RECEPTACLE (PART OF REAR PANEL) (PART OF W2)	82389	EAC-301
J1						
J2						
J3						
L1	9100-1618	1	1	PART OF W3	28480	9100-1618
MP1	08447-00005	6	1	COIL: MOLDED CHOKE 5.60 UH	28480	08447-00005
Q1	1854-0063	7	1	INSULATOR: TOP COVER	80131	2N3055
R1	0683-2735	0	1	TSTR: SI NPN	01121	CB 2735
S1	3101-2195	7	1	R:FXD COMP 27K OHM 5% 1/4W	04757	53-67600-123
S1	0590-0012	5	2	SWITCH-PB DPST-NO ALTNG 10.5A 250VAC	04009	899U-3
S2	3101-1234	3	1	NUT: KNURLED 15/32-32	82389	11A-1242
T1	9100-2894	7	1	SWITCH: SLIDE DPDT (P/O REAR PANEL)	28480	9100-2894
U1	0960-2014	6	1	TRANSFORMER: POWER	28480	0960-2014
W1	8120-1348	5	1	HYBRID MC: POWER AMPL 0.1-1300MHZ	70903	KHS-7041
W2	08447-20002	5	1	CABLE ASSY: POWER, DETACHABLE	28480	08447-20002
W2				CABLE ASSY: TYPE N INPUT (OPTION 010)		
W2	08447-20006	9	1	CABLE ASSY: BNC INPUT (STANDARD)	28480	08447-20006
W3	08447-20003	6	1	CABLE ASSY: TYPE N OUTPUT (OPTION 010)	28480	08447-20003
W3	08447-20007	0	1	CABLE ASSY: BNC OUTPUT (STANDARD)	28480	08447-20007
W3						
XF1				FUSEHOLDER (INCLUDES THE FOLLOWING PARTS)		
XF1MP1	2110-0564	8	1	FUSEHOLDER BODY 12A MAX FOR UL	28480	2110-0564
XF1MP2	2110-0565	9	1	FUSEHOLDER CAP 12A MAX FOR UL	28480	2110-0565
XF1MP3	2110-0569	3	1	NUT-FUSEHOLDER THREAD	28480	2110-0569
XQ1	1200-0043	8	1	INSULATOR: TSTR MOUNTING (TO-3)	71785	293011
	0360-0368	7	1	TERMINATION: SOLDER STUD	78189	2168-12-01
	0900-0016	8	1	"O" RING: 0.688" OD	00000	OBD
	2190-0037	9	1	WASHER: LOCK INT. FOR 0.500" THREAD	78189	1224-08

Table 6. 8447F Replaceable Parts

Reference Designation	HP Part Number	C D	Qty	Description	Mfr Code	Mfr Part Number
A1	08447-60011	0	1	BOARD ASSY; POWER SUPPLY	28480	08447-60011
A1C1	0150-0024	7	13	C:FXD CER 0.02 UF +80-20% 600 VDCW	71590	TYPE DD 203
A1C2	0180-0228	6	1	C:FXD ELECT 22 UF 10% 15VDCW	56289	150D226X9015B2-DYS
A2C3	0160-0162	5	1	C:FXD MY 0.022 UF 10% 200VDCW	56289	192P22392-PTS
A2C4	0180-0116	1	1	C:FXD ELECT 6.8 UF 10% 35VDCW	56289	150D685X9035B2-OYS
A1C5	0180-1819	3	1	C:FXD ELECT 100 UF +75-10% 50VDCW	28480	0180-1819
A1CR1	1901-0159	3	4	DIODE:SILICON 0.75A 400PIV	02037	SR1358-4
A1CR2	1901-0159	3	4	DIODE:SILICON 0.75A 400PIV	02037	SR1358-4
A1CR3	1901-0159	3	4	DIODE:SILICON 0.75A 400PIV	02037	SR1358-4
A1CR4	1901-0159	3	4	DIODE:SILICON 0.75A 400PIV	02037	SR1358-4
A1CR5	1902-3036	3	1	DIODE: BREAKDOWN 3.16V 5%	02037	SZ10939-38
A1CR6	1902-0761	5	1	DIODE: BREAKDOWN 5.9 to 6.5V	12954	1N821
A1CR7	1901-0265	3	2	DIODE:SILICON 100MA/1V	07263	FD 2387
A1CR8	1902-3268	3	1	DIODE: BREAKDOWN:26.1V 5%	28480	1902-3268
A1CR9	1884-0073	2	1	THYRISTER:SCR TO-5 VRRM=100	01921	SCR1400
A1CR10	1901-0025	2	2	DIODE:SILICON 100MA/1V	07263	FD 2387
A1F1	2110-0012	0	1	FUSE:0.5 AMP 250V	04703	312.500
A1F1	2110-0269	9	2	CLIP:FUSE 0.250" DIA	91506	6008-32CN
A1Q1	1853-0012	4	1	TSTR:SI NPN	80131	2N2904A
A1Q2	1854-0022	8	1	TSTR:SI NPN	07263	S17843
A1Q3	1854-0071	7	3	TSTR:SI NPN (SELECTED FROM 2N3704)	28480	1854-0071
A1Q4	1854-0071	7	3	TSTR:SI NPN (SELECTED FROM 2N3704)	28480	1854-0071
A1Q5	1854-0071	7	3	TSTR:SI NPN (SELECTED FROM 2N3704)	28480	1854-0071
A1R1	0757-0836	5	2	R:FXD MET FLM 7.50K OHM 1% 1/2W	28480	0757-0836
A1R2	0757-0278	9	1	R:FXD MET FLM 1.78K OHM 1% 1/8W	28480	0757-0278
A1R3	0757-0836	5	2	R:FXD MET FLM 7.50K OHM 1% 1/2W	28480	0757-0836
A1R4	0811.1668	9	1	R:FXD WW 1.5 OHM 5% 2W	28480	0811-1668
A1R5	0698-0089	4	1	R:FXD MET FLM 1780 OHM 1% 1/2W	28480	0698-0089
A1R6	0698-0083	8	1	R:FXD MET FLM 1.96K OHM 1% 1/8W	28480	0698-0083
A1R7	0698-3440	7	1	R:FXD MET FLM 196 OHM 1% 1/8W	28480	0698-3440
A1R8	0757-0416	7	1	R:FXD MET FLM 511 OHM 1% 1/8W	28480	0757-0416
A1R9	2100-1758	3	1	R:VAR WW 1K OHM 5% TYPE V 1W	28480	2100-1758
A1R10	0698-3154	0	1	R:FXD MET FLM 4.22K OHM 1% 1/8W	28480	0698-3154
A1R11	0757-1094	9	1	R:FXD MET FLM 1.47K OHM 1% 1/8W	28480	0757-1094
A1R12	0698-3442	9	1	R:FXD MET FLM 237 OHM 1% 1/8W	28480	0698-3442
A1R13	0757-0180	2	1	R:FXD MET FLM 31.6 OHM 1% 1/8W	28480	0757-0180
A1R14	0757-0401	0	1	R:FXD MET FLM 100 OHM 1% 1/8W	28480	0757-0401
A1TB1	08447-20011	6	1	BOARD:BLANK PC	28480	08447-20011
C1	0180-2272	4	1	C:FXD ELECT 850 UF +50-10% 75VDCW	56289	36D851F075AA2A DQB
C2	0160-2049	1	1	C:FXD CER FEED-THRU 5000 PF +80-20%	28480	0160-2049
C3	0180-0291	3	1	C:FXD ELECT 1.0 UF 10% 35VDCW	56289	150D105X9035A2-DYS
DS1	2140-0244	4	1	LAMP:GLOW MINIATURE 95V	87034	A1H
F1	2110-0012	1	1	FUSE:0.5 AMP 250V	04703	312.500
J1	1251-2357	8	1	SOCKET:3-PIN MALE POWER RECEPTACLE (PART OF REAR PANEL)	82389	EAC-301
J2				PART OF W2		
J3				PART OF W3		
J4				PART OF W4		
J5				PART OF W5		
L1	9100-1618	1	2	COIL:MOLDED CHOKE 5.60 UH	28480	9100-1618
L2	9100-1618	1	2	COIL:MOLDED CHOKE 5.60 UH	28480	9100-1618
MP1	08447-00005	6	1	INSULATOR:TOP COVER	28480	08447-00005
MP2	08447-00028	3	1	SUPPORT:AMPLIFIER	28480	08447-00028
Q1	1854-0063	7	1	TSTR:SI NPN	80131	2N3055
R1	0683-2735	0	1	R:FXD CPB 27K OHM 5% 1/4W	01121	CB 2735
S1	3101-2195	7	1	SWITCH-PB DPST-NO ALTNG 10.5A 250VAC	04757	53-67600-123
S1	0590-0012	5	2	NUT:KNURLED 15/32-32	04009	899U-3
S2	3101-1234	3	1	SWITCH:SLIDE DPDT (PART OF REAR PANEL)	82389	11A-1242
T1	9100-2894	7	1	TRANSFORMER:POWER	28480	9100-2894
U1	0960-2014	6	1	HYBRID MC:POWER AMPL 0.1-1300 MHZ	28480	0960-2014
U2	0960-2013	5	1	HYBRID MC:PRE-AMPL 0.1-1300 MHZ	28480	0960-2013
W1	8120-1348	5	1	CABLE ASSY:POWER, DETACHABLE	70903	KHS-7041
W2	08447-20002	5	1	CABLE ASSY:TYPE N INPUT (OPT 010)	28480	08447-20002
W2	08447-20006	9	1	CABLE ASSY:BNC INPUT	28480	08447-20006
W3	08447-20003	6	1	CABLE ASSY:TYPE N OUTPUT (OPT 010)	28480	08447-20003
W3	08447-20007	0	1	CABLE ASSY:BNC OUTPUT	28480	08447-20007
W4	08447-20004	7	1	CABLE ASSY:TYPE N INPUT (OPT 010)	28480	08447-20004
W4	08447-20008	1	1	CABLE ASSY:BNC INPUT	28480	08447-20008
W5	08447-20005	8	1	CABLE ASSY:TYPE N OUTPUT (OPT 010)	28480	08447-20005
W5	08447-20009	2	1	CABLE ASSY:BNC OUTPUT	28480	08447-20009
W6	08447-20014	9	1	CABLE ASSY:JUMPER (OPT 010 ONLY)	28480	08447-20014
XF1				FUSEHOLDER (INCLUDES THE FOLLOWING PARTS)		
XF1MP1	2110-0564	8	1	FUSEHOLDER BODY 12A MAX FOR UL	28480	2110-0564
XF1MP2	2110-0565	9	1	FUSEHOLDER CAP 12A MAX FOR UL	28480	2110-0565
XF1MP3	2110-0569	3	1	NUT:FUSEHOLDER THREAD	28480	2110-0569
XQ1	1200-0043	8	1	INSULATOR:TSTR MOUNTING (TO-3)	71785	293011
	0360-0368	7	1	TERMINATION:SOLDER STUD	78189	2168-12-01
	0900-0016	8	1	"O" RING: 0.688" OD	00000	OBD
	2190-0037	9	1	WASHER:LOCK INT. FOR 0.500" THREAD	78189	1224-08

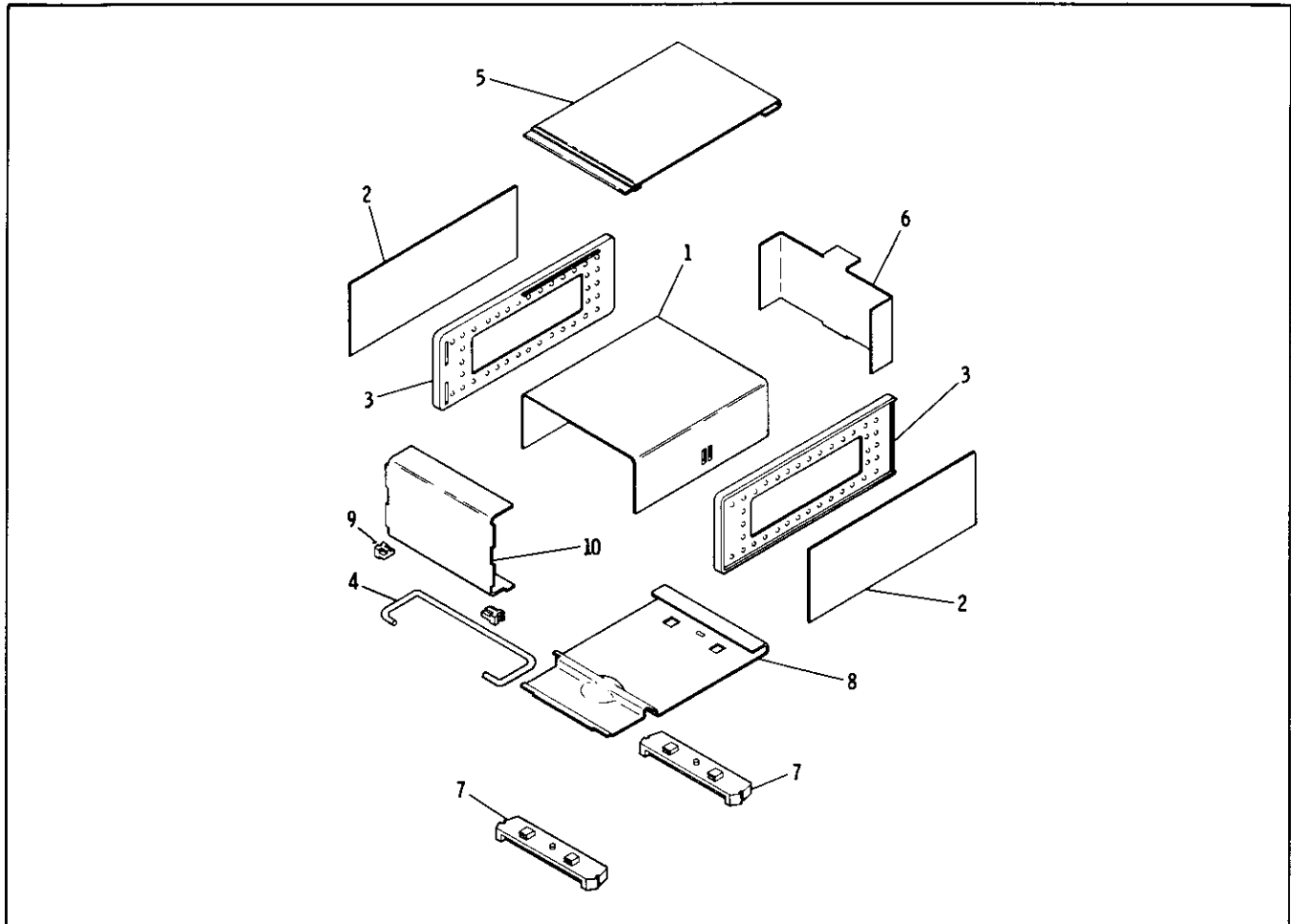

Index Number	Part Number	C D	Description	Qty
1	08447-00029	4	DECK MAIN	1
2	5000-7891	8	SIDE COVER-BLUE GRAY	1
2	5000-8766	8	SIDE COVER-OLIVE GRAY	2
3	5060-0247	0	FRAME ASSEMBLY	2
4	1490-0031	7	STAND TILT	1
5	5060-0708	8	TOP COVER-BLUE GRAY	1
5	5060-8553	7	TOP COVER-OLIVE GRAY	1
6	08447-00050	0	PANEL REAR	1
7	5060-0727	1	FOOT ASSEMBLY	2
8	5000-0710	6	BOTTOM COVER-BLUE GRAY	1
8	5000-8569	9	BOTTOM COVER-OLIVE GRAY	1
9	5040-0700	8	HINGE	2
10	08447-00017	0	PANEL:FRONT (8447D STANDARD)-LIGHT GRAY	1
	08447-00018	1	PANEL:FRONT (8447D OPTION 001)-LIGHT GRAY	1
	08447-00019	2	PANEL:FRONT (8447D OPTION 010)-LIGHT GRAY	1
	08447-00021	6	PANEL:FRONT (8447D OPTION 011)-LIGHT GRAY	1
	08447-00022	7	PANEL:FRONT (8447E STANDARD)-LIGHT GRAY	1
	08447-00023	8	PANEL:FRONT (8447E OPTION 010)-LIGHT GRAY	1
	08447-00024	9	PANEL:FRONT (8447F STANDARD)-LIGHT GRAY	1
	08447-00025	0	PANEL:FRONT (8447F OPTION 010)-LIGHT GRAY	1
	08447-00040	9	PANEL:FRONT (8447D STANDARD)-MINT GRAY	1
	08447-00041	0	PANEL:FRONT (8447D OPTION 001)-MINT GRAY	1
	08447-00042	1	PANEL:FRONT (8447D OPTION 010)-MINT GRAY	1
	08447-00043	2	PANEL:FRONT (8447D OPTION 011)-MINT GRAY	1
	08447-00044	3	PANEL:FRONT (8447E STANDARD)-MINT GRAY	1
	08447-00045	4	PANEL:FRONT (8447E OPTION 010)-MINT GRAY	1
	08447-00046	5	PANEL:FRONT (8447F STANDARD)-MINT GRAY	1
	08447-00047	6	PANEL:FRONT (8447F OPTION 010)-MINT GRAY	1

Figure 11. 8447D/E/F Cabinet Parts

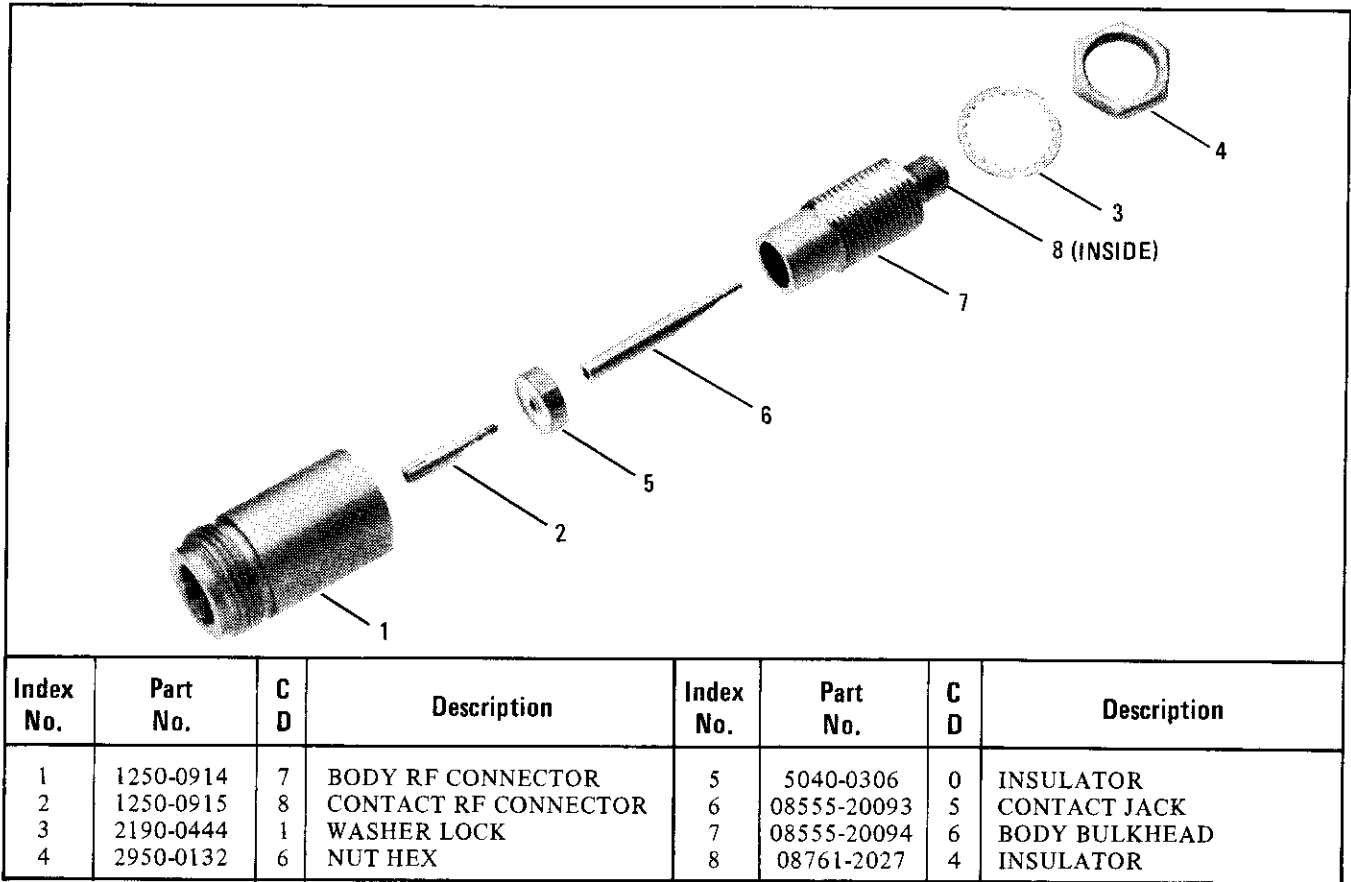

Figure 12. 8447D/E/F Type N Connector (For Options 010 and 011)

Table 7. Code List of Manufacturers

Mfr. No.	Manufacturer Name	Address	Zip Code
01121	ALLEN BRADLEY CO.	MILWAUKEE, WI	53204
01921	RCA SOLID STATE DIV.	SOMERVILLE, NJ	08876
02037	MOTOROLA SEMICONDUCTOR PRODUCTS	PHOENIX, AZ	85008
04009	ARROW, HART & HEGEMAN ELECT. CO.	HARTFORD, CT	06106
04703	LITTELFUSE INC.	DES PLAINES, IL	60016
04757	OAK IND. INC., SW DIV.	CRYSTAL LAKE, IL	60014
07263	FAIRCHILD CAMERA & INSTR. CORP., SEMICONDUCTOR DIV.	MOUNTAIN VIEW, CA	94040
12954	DICKSON ELECTRONIC CORP.	SCOTTSDALE, AZ	85282
28480	HEWLETT-PACKARD CO.	PALO ALTO, CA	94304
56289	SPRAGUE ELECTRIC CO.	N. ADAMS, MA	01247
70903	BELDEN CORP.	CHICAGO, IL	60644
71590	GLOBE UNION INC. CENTRAL LAB DIV.	MILWAUKEE, WI	53201
71785	CINCH MFG. CO., DIV TRW INC.	ELK GROVE VILLAGE, IL	
78189	SHAKEPROOF DIV. ILLINOIS TOOL WORKS	ELGIN, IL	60120
80131	ELECTRONIC INDUSTRIES ASSOCIATION	WASHINGTON, DC	20006
82389	SWITCHCRAFT INC.	CHICAGO, IL	60630
87034	MARCOAK INDUSTRIES	ANAHEIM, CA	92803
91506	AUGAT, INC.	ATTLEBORO, MA	02703

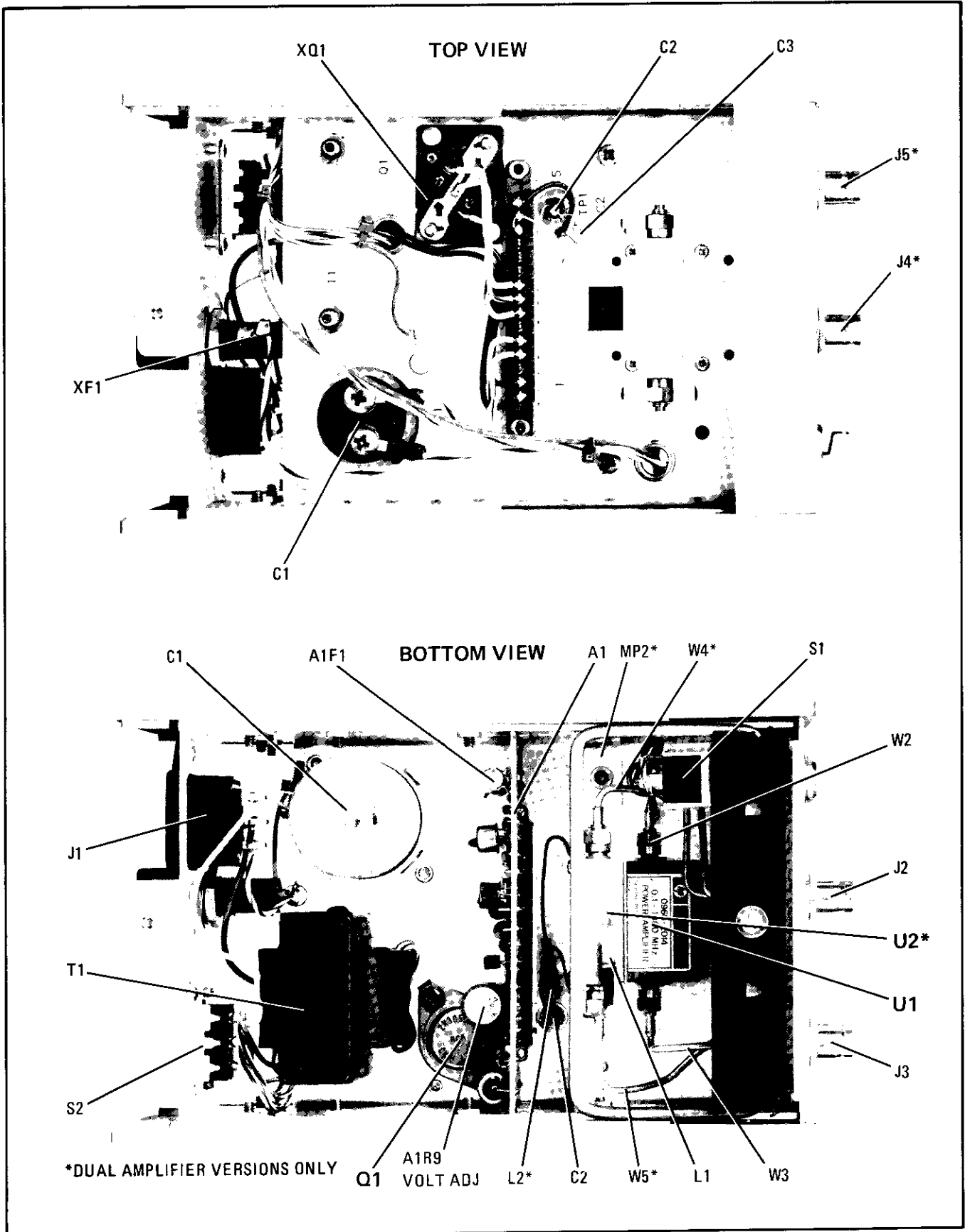

Figure 13. Internal Views

**65. TEST EQUIPMENT AND ACCESSORIES
REQUIRED FOR TROUBLESHOOTING**

66. Test Equipment and accessories required to troubleshoot the amplifier are shown in Table 2. Test instruments other than those listed may be used provided their specifications meet or exceed those listed in Table 2.

67. GENERAL SERVICE INFORMATION

68. The part reference designator is the assembly designator plus the part designator. (Example: A1R9 is R9 on the A1 Power Supply Assembly.) Refer to the parts list on Table 4, 5 or 6 for specific component description for ordering parts.

69. TROUBLESHOOTING PROCEDURE

70. First check the input and output cables. Isolate trouble to the amplifier(s) or power supply by checking the +20 volts at XA1-14 after removing the red wire from C2. If the voltage is present, replace the amplifier (re-attach the red wire to C2). If voltage is not present or incorrect, check the power supply. The voltages shown are typical with the amplifier(s) disconnected from the power supply.

Equipment:

- Digital Voltmeter HP 3440A/344A
- Cable Assembly (w/test clips) HP 10501A
- Adapter HP 10111A

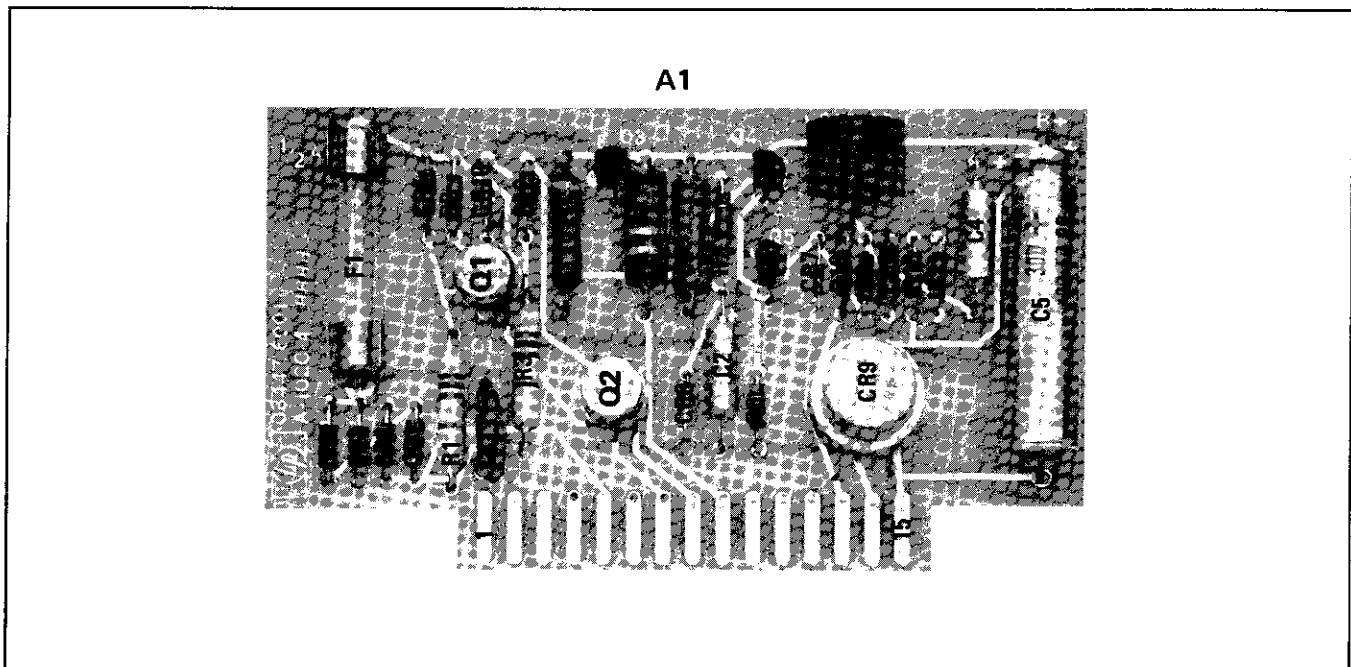

Figure 14. A1 Power Supply Component Locations

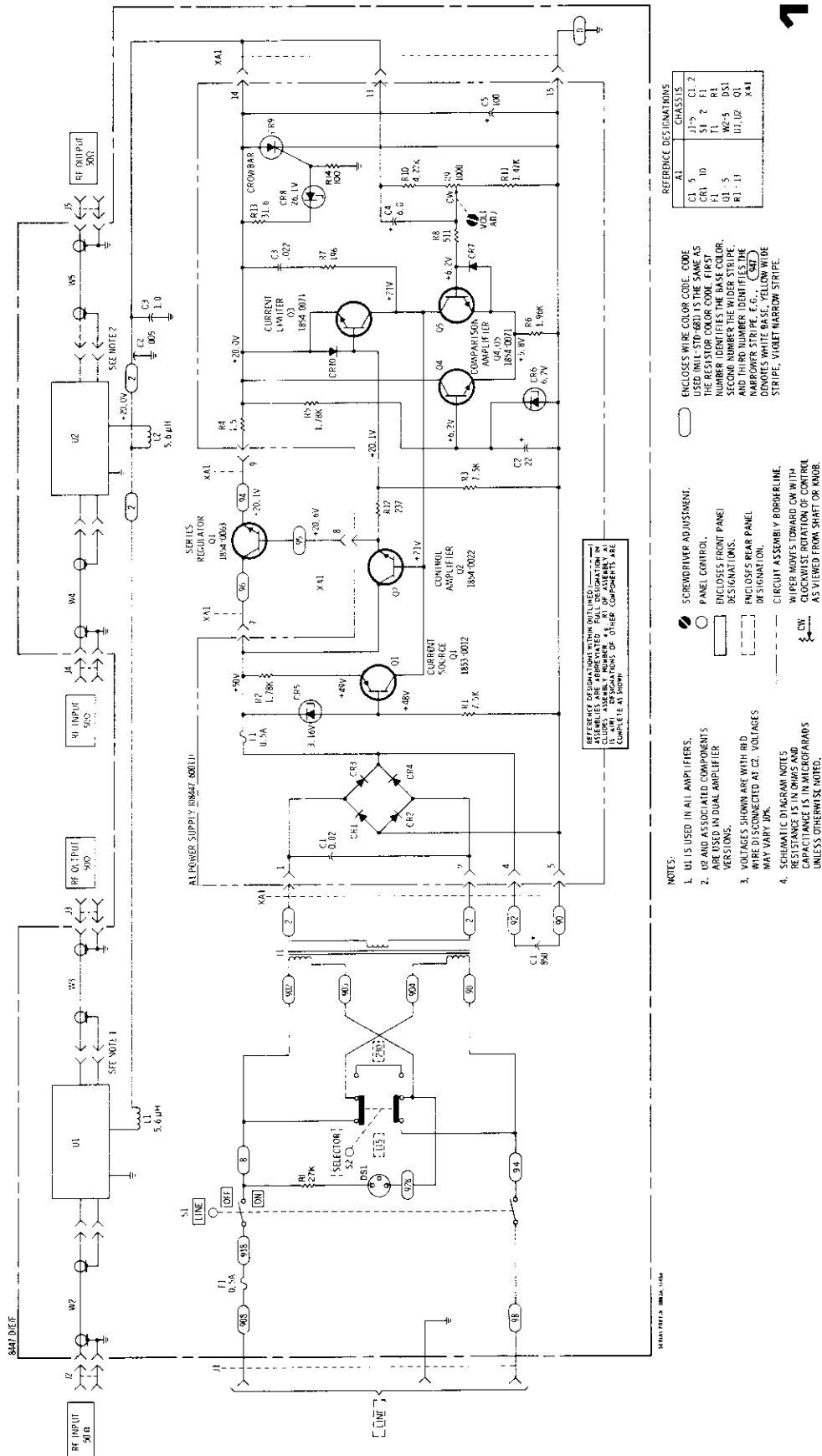

Figure 15. Amplifier and Power Supply Circuits

71. MANUAL BACKDATING CHANGES

72. The following paragraphs contain information for adapting this manual to instruments for which the content does not apply directly.

73. To adapt this manual to your instrument, refer to Table 8 and make all of the manual changes listed opposite your instrument serial number.

Perform these changes in the alphabetical sequence listed.

74. If your instrument serial number is not listed on the title page of this manual, or in Table 8 below, it may be documented in a yellow MANUAL CHANGES supplement. For additional important information about serial number coverage, refer to INSTRUMENTS COVERED BY MANUAL.

Table 8. Manual Changes by Serial Number Prefix

Serial Prefix	Make Manual Changes
1726A	A
1644A	A, B
1616A	A, B, C
1529A, 1145A, 0993A	A, B, C, D

75. MANUAL CHANGE INSTRUCTIONS

CHANGE A

Pages 21 through 23, Tables 4 through 6:

Change XF1MP1 to HP Part Number 2110-0470, Check Digit 5, Qty 1, FUSEHOLDER BODY EXTR PST; BAYONET; TND, 04703, 345003-010.

Change XF1MP2 to HP Part Number 2110-0465, Check Digit 8, Qty 1, FUSEHOLDER CAP EXTR PST; BAYONET; 20A, 04703, 345001-020.

Change XF1MP3 to HP Part Number 2110-0467, Check Digit 0, Qty 1, FUSEHOLDER COMPONENT HEX NUT: 1/2-28, 04703, 903-070.

Add XF1MP4, HP Part Number 1400-0090, Check Digit 9, Qty 1, FUSEHOLDER COMPONENT FOR USE ON, 04703, 901-002.

CHANGE B

Page 1, Table 1:

Change Mean Gain (20°–30°C) to “26 dB ±1.5 dB” for 8447D PRE AMP and 8447F PRE AMP.

Page 9, Paragraph 55:

Under Specifications, change Mean Gain (20°–30°C) to “26 dB ±1.5 dB” for 8447D PRE AMP and 8447F PRE AMP.

CHANGE B (Cont'd)

Page 11, Paragraph 55, Step 10.:

Change the sentence to read: "Add the highest and lowest gains together and divide by 2; the result is measured mean gain and should be within 1.5 dB of specified mean gain."

In step 10, under EXAMPLE, change Mean Gains as follows:

Mean Gain	MIN.	ACTUAL	MAX.
8447D	24.5 dB		27.5 dB
8447E	20.5 dB		23.5 dB
8447F PRE AMP	24.5 dB		27.5 dB
8447F POWER AMP	20.5 dB		23.5 dB

CHANGE C

Pages 21 through 23, Tables 4 through 6:

Change first S1 entry to HP Part Number 3101-1244, Check Digit 5, Qty 1, SWITCH-PB SPDT-DB ALTNG 10.5A 250VAC, 04757, 53-55480-120/A1N.

Change XF1 to 1400-0084, Check Digit 1, Qty 1, FUSEHOLDER-EXTR POST 15A 250 V UL, 04703, 342014.

Delete entries XF1MP1, XF1MP2, XF1MP3, and XF1MP4.

Add as part of XQ1, HP Part Number 2950-0038, Check Digit 1, Qty 1, NUT-SPCLY 1/2-24-THD .125-IN-THK, 04703, 903-12.

Page 24, Figure 11:

Change Index Number 6 to HP Part Number 08447-00002, Check Digit 3, PANEL REAR, Qty 1.

Page 28, Figure 15:

At S1 LINE switch, delete switch connection between wire numbers 98 and 94. Change wire number 94 to wire number 90 and draw a jumper between wire numbers 98 and 90.

CHANGE D

Pages 21 through 23, Tables 4 through 6:

Change A1CR9 to HP Part Number 1884-0012, Check Digit 9, Qty 1, THYRISTER: SCR 2N358 TO-8 VRRM=200, 01921, 2N3528.

Delete A1R14, HP Part Number 0757-0401, Check Digit 0, Qty 1, R:FXD MET FLM 100 OHM 1% 1/8W.

Page 28, Figure 15:

Delete resistor R14 and its connection to ground.

Supersedes:

None

HP MODEL 8447A AMPLIFIER

All Serials

PREVENTION OF AMPLIFIER DAMAGE DUE TO ELECTROSTATIC DISCHARGE**CAUTION**

The input to the 8447A amplifier is very susceptible to damage from electrostatic discharge.

Before connecting any coaxial cable to the input jack of the amplifier, make certain that static electricity buildup in the cable is completely discharged. This is best accomplished by shorting the inner conductor of the cable to the outer conductor while simultaneously touching earth ground. A small open-end wrench can be used to short the inner conductor to the outer conductor, and the output jack of the amplifier provides a good earth ground to which the other end of the wrench can be touched. The other end of the coaxial cable should be connected first before going through this procedure. If the other end of the cable is connected to a signal source, make sure the source's power has been turned off.

A static-safe work station is highly recommended when handling the coaxial cable. Such a station should include a wrist strap in contact with bare skin connected to a conductive table mat through a current-limiting one-megohm resistor. The table mat must be connected to earth ground through another one-megohm resistor.

Once the coaxial cable is connected to the amplifier input, a discharge path to ground is established. Thus, any static electricity buildup on the cable will be bled off. Handling precautions will not be necessary with the cable connected.

I/NS/WN

11/84-53/BA



FOR MORE INFORMATION, CALL YOUR LOCAL HP SALES OR SERVICE OFFICE or East (201) 265-5000 • Midwest (312) 255-9800 • South (404) 955-1500 • West (213) 970-7500 or (415) 968-9200 OR WRITE, Hewlett-Packard, 1820 Embarcadero, Palo Alto, California 94303. IN EUROPE, CALL YOUR LOCAL HP SALES OR SERVICE OFFICE OR WRITE, Hewlett-Packard S.A., 7, rue du Bois-du-Lan, P.O. Box, CH-1217 Meyrin 2-Geneva, Switzerland. IN JAPAN, Yokogawa-Hewlett-Packard Ltd., 1-27-15, Yabe Sagaminara City, Kanagawa Prefecture, Japan 229.

MANUAL CHANGES

MANUAL IDENTIFICATION

Model Number: 8447D/E/F
Date Printed: SEPT. 1980
Part Number: 08447-90033

This supplement contains important information for correcting manual errors and for adapting the manual to instruments containing improvements made after the printing of the manual.

To use this supplement:

Make all ERRATA corrections

Make all appropriate serial number related changes indicated in the tables below.

	Serial Prefix or Number	Make Manual Changes		Serial Prefix or Number	Make Manual Changes
8447D	1937A03460,-03465, and 2432A	1			
	2443A	2			
	2648A	5			
	▶ 2727A	6			
8447E	1937A01890,-01891, -01893,-01894,-01898, -01899,-01900,-01903, -01904,-01906,-01908, -01911, and 2434A	1	▶	8447E 2727A	6
	2434A02189, -02192 thru -02196, -02216, -02218,-02221,-02222, and 2631A	4			
8447F	1937A01513,-01519, -01521,-01523 thru -01530, and 2430A	1	▶	8447F 2727A	6
	2443A	3			
	2443A01932, -01957, -01965,-01971 thru -01973,-01975,-01993 thru 01996, -01998, -01999, -02000 and 2634A	4			

▶ NEW ITEM

NOTE

Manual change supplements are revised as often as necessary to keep manuals as current and accurate as possible. Hewlett-Packard recommends that you periodically request the latest edition of this supplement. Free copies are available from all HP offices. When requesting copies quote the manual identification information from your supplement, or the model number and print date from the title page of the manual.

1 November 1987



ERRATA

Page 8, Paragraph 43:

After the first sentence in step c, add the following caution:

CAUTION

The input to the 8447D/E/F amplifier is very susceptible to damage from electrostatic discharge. Before connecting any coaxial cable to the input jack of the amplifier, make certain that static electricity buildup in the cable is completely discharged.

Page 21, Table 4:

Change A1CR1-4 to HP Part Number 1901-0743, Check Digit 1, DIODE:PWR RECT IN4004 400VIA DO-41.

Change U1 and U2 (for Standard and Options 010 and 011) to HP Part Number 5086-7005, Check Digit 6.

Change XQ1 to HP Part Number 0340-0664, Check Digit 4, INSULATOR-XSTR TO-3.

Page 22, Table 5:

Change A1CR1-4 to HP Part Number 1901-0743, Check Digit 1, DIODE:PWR RECT IN4004 400VIA DO-41.

Change XQ1 to HP Part Number 0340-0664, Check Digit 4, INSULATOR-XSTR TO-3.

Page 23, Table 6:

Change A1CR1-4 to HP Part Number 1901-0743, Check Digit 1, DIODE:PWR RECT IN4004 400VIA DO-41.

Change U2 to HP Part Number 5086-7005, Check Digit 6.

Change XQ1 to HP Part Number 0340-0664, Check Digit 4, INSULATOR-XSTR TO-3.

Page 24, Figure 11:

Delete HP Part Numbers 08447-00017, 08447-00018, 08447-00019, 08447-00021, 08447-00022, 08447-00023, 08447-00024, 08447-00025, 08447-00040, 08447-00041, 08447-00042, 08447-00043, 08447-00044, 08447-00045, 08447-00046, and 08447-00047 from Index Number 10.

Add to Index Number 10:

HP Part Number 08447-00058, Check Digit 9, PANEL: FRONT (8447D STANDARD).

HP Part Number 08447-00059, Check Digit 0, PANEL: FRONT (8447D OPTION 001).

HP Part Number 08447-00060, Check Digit 3, PANEL: FRONT (8447D OPTION 010).

HP Part Number 08447-00061, Check Digit 4, PANEL: FRONT (8447D OPTION 011).

HP Part Number 08447-00062, Check Digit 5, PANEL: FRONT (8447E STANDARD).

HP Part Number 08447-60063, Check Digit 6, PANEL: FRONT (8447E OPTION 010).

HP Part Number 08447-00064, Check Digit 7, PANEL: FRONT (8447F STANDARD).

HP Part Number 08447-00065, Check Digit 8, PANEL: FRONT (8447F OPTION 010).

Page 27, Figure 14:

Replace Figure 14 with the new Figure 14, A1 Power Supply Component Locations (ERRATA), included in this Manual Changes supplement.

CHANGE 1

Page 1, Table 1:

For the 8447D and 8447F PRE AMP Specifications, make the following change:

Change the Mean Gain from 26 dB to 25 dB.

For the 8447E and 8447F POWER AMP Specifications, make the following changes:

Change the Mean Gain from 22 dB \pm 1.5 dB to 22 dB \pm 2.0 dB.

Change the Output Power for 1 dB Gain Compression from $>$ +15 dBm to $>$ +14 dBm.

Page 9, Paragraph 55:

In the table at the top of page 9, make the following changes:

For the 8447D and 8447F PRE AMP Specifications, make the following change:

Change the Mean Gain from 26 dB to 25 dB.

For the 8447E and 8447F POWER AMP Specifications, make the following changes:
 Change the Mean Gain from 22 dB \pm 1.5 dB to 22 dB \pm 2.0 dB.
 Change the Output Power for 1 dB Gain Compression from $>$ +15 dBm to $>$ +14 dBm.
 In the "Description" paragraph, change the third sentence to read: "Half of the sum of the highest gain and lowest gain is the measured mean gain and should be within 2.0 dB of the specified gain."

Page 11, Paragraph 55:

In the example at the bottom of the page, change data recording section as follows:

Min.	Actual	Max.
25 dB	_____	
20.0 dB	_____	24.0 dB
25 dB	_____	
20.0 dB	_____	24.0 dB

Page 12, Paragraph 55:

In step 11, change the signal level reading on the power meter to:

8447E: +4 dBm (+14 dBm ampl. output)

8447F POWER AMP: +4 dBm (+14 dBm ampl. output)

In step 13, change the reading of the power meter to:

8447E: less than +5 dBm: _____ +5 dBm

8447F POWER AMP: less than +5 dBm: _____ +5 dBm

Page 24, Figure 11:

Delete HP Part Numbers 08447-00058, 08447-00059, 08447-00060, 08447-00061, 08447-00064, and 08447-00065 from Index Number 10.

Add to Index Number 10:

- HP Part Number 08447-00070, Check Digit 5, PANEL: FRONT (8447D STANDARD).
- HP Part Number 08447-00071, Check Digit 6, PANEL: FRONT (8447D OPTION 001).
- HP Part Number 08447-00072, Check Digit 7, PANEL: FRONT (8447D OPTION 010).
- HP Part Number 08447-00073, Check Digit 8, PANEL: FRONT (8447D OPTION 011).
- HP Part Number 08447-00074, Check Digit 9, PANEL: FRONT (8447F STANDARD).
- HP Part Number 08447-00075, Check Digit 0, PANEL: FRONT (8447F OPTION 010).

CHANGE 2

Page 24, Figure 11:

Delete HP Part Numbers 08447-00058, 08447-00059, 08447-00060, and 08447-00061 from Index Number 10.

Add to Index Number 10:

- HP Part Number 08447-00070, Check Digit 5, PANEL: FRONT (8447D STANDARD).
- HP Part Number 08447-00071, Check Digit 6, PANEL: FRONT (8447D OPTION 001).
- HP Part Number 08447-00072, Check Digit 7, PANEL: FRONT (8447D OPTION 010).
- HP Part Number 08447-00073, Check Digit 8, PANEL: FRONT (8447D OPTION 011).

CHANGE 3

Page 24, Figure 11:

Delete HP Part Numbers 08447-00064 and 08447-00065 from Index Number 10.

Add to Index Number 10:

- HP Part Number 08447-00074, Check Digit 9, PANEL: FRONT (8447F STANDARD).
- HP Part Number 08447-00075, Check Digit 0, PANEL: FRONT (8447F OPTION 010).

CHANGE 4

Page 1, Table 1:

► In the left-hand column of the specifications table, change "VSWR, 1 to 1300 MHz" to "VSWR, 1 to 1300 MHz".

Under 8447E POWER AMP specifications, make the following changes:

Change Typical 3 dB Bandwidth to "0.075 to 1400 MHz".

Change Output Power for 1 dB Gain Compression to " $>$ +12.5 dBm from 0.1 to 1000 MHz".

- Change Harmonic Distortion to "-30 dB for +8 dBm output".
- Change VSWR, 1 to 1300 MHz to "<2.2:1 INPUT, <2.5:1 OUTPUT".
- Under 8447E POWER AMP specifications, make the following changes:
 - Change Typical 3 dB Bandwidth to "0.075 to 1400 MHz".
 - Change Output Power for 1 dB Gain Compression to ">=+12.5 dBm from 0.1 to 1000 MHz".
 - Change Harmonic Distortion to "-30 dB for +8 dBm output".
 - Change VSWR, 1 to 1300 MHz to "<2.2:1 INPUT, <2.5:1 OUTPUT".

Page 22, Table 5:

Change U1 to HP Part Number 5086-7768, Check Digit 8.

Page 23, Table 6:

Change U1 to HP Part Number 5086-7768, Check Digit 8.

Page 9, Specifications:

Change 8447E and 8447F POWER AMP Output Power for 1 dB Gain Compression to +12.5 dBm.

Page 12, Paragraph 55:

In step 11, change the signal level reading on the power meter to:

- 8447E: +2.5 dBm (+12.5 dBm Amplitude Output)
- 8447F POWER AMP +2.5 dBm (+12.5 dBm Amplitude Output)

In step 13, change the reading of the power meter to:

- 8447E less than +3.5 dBm _____ +3.5 dBm
- 8447F POWER AMP less than +3.5 dBm _____ +3.5 dBm

In Paragraph 56, under Specification, change 8447E POWER AMP and 8447F POWER AMP to <2.2 INPUT, <2.5 OUTPUT

Page 14, Paragraph 56:

Change the second sentence in step 5 to: The measured return loss should be as shown below:

- 8447D OUTPUT VSWR, 1 TO 110 MHz: 8.8 dB
- 8447E/F 7.7 dB

Page 15, Paragraph 56:

Change the second sentence in step 10 to: The measured return loss should be as shown below:

- 8447D OUTPUT VSWR, 1 TO 110 MHz: 8.8 dB
- 8447E/F 7.7 dB

In the table after step 11, add 8447D OUTPUT to 8447E INPUT, 8447E POWER AMP INPUT in the fourth column. Add 8447E and 8447F to OUTPUT in the fifth column. Change the sweep range values in the fifth column from +8.8 dB to +7.7 dB.

In Paragraph 57, change 8447E POWER AMP and 8447F POWER AMP Harmonic Distortion to -30 dB for +8 dBm output.

Page 16, Paragraph 57:

Under step 3, change the Signal Levels out of the amplifier for the 8447E and 8447F POWER AMP from +10 dBm to +8 dBm.

CHANGE 5

Page 1, Table 1:

Under 8447D PRE AMP specifications, make the following change:

Change Typical 3 dB Bandwidth to "0.075 to 1700 MHz (Standard and Option 010 Only)".

Page 21, Table 4:

Change U1,U2 HP Part Number from 5086-7005 to 5086-7767 (for Standard and Option 010 Only), Check Digit 7 (5086-7005 previously 0960-2013).

CHANGE 6

Page 1, Table 1:

Under 8447D Pre Amp specifications, make the following change:

Change Typical 3 dB Bandwidth LO "0.075 to 1700 MHz (Standard and Options 001 and 011)."

Under 8447F Pre Amp specifications make the following change:

Change Typical 3 dB Bandwidth LO to "0.075 to 1700 MHz."

Page 21, Table 4:

Change U1,U2 HP Part Number from 5086-7005 to 5086-7767 (for Options 001 and 011), Check Digit 7 (5086-7005 previously 0960-2013).

Change A1 HP Part Number from 08447-60011 to 08447-60045, Check Digit 0.

Change A1CR5 HP Part Number from 1902-3036 to 1920-3002, Check Digit 1.

Change ALR2 HP Part Number from 0757-0278 to 0698-7238, Check Digit 9.

Change ALR4 HP Part Number from 0811-1668 to 0811-1732, Check Digit 8.

Change C1 HP Part Number from 0180-2272 to 0180-2805, Check Digit 9.

Page 22, Table 5:

Change A1 HP Part Number from 08447-60011 to 08447-60045, Check Digit 0.

Change A1CR5 HP Part Number from 1902-3036 to 1920-3002, Check Digit 1.

Change ALR2 HP Part Number from 0757-0278 to 0698-7238, Check Digit 9.

Change ALR4 HP Part Number from 0811-1668 to 0811-1732, Check Digit 8.

Change C1 HP Part Number from 0180-2272 to 0180-2805, Check Digit 9.

Page 23, Table 6:

Change U1,U2 HP Part Number from 5086-7005 to 5086-7767, Check Digit 7 (5086-7005 previously 0960-2013).

Change A1 HP Part Number from 08447-60011 to 08447-60045, Check Digit 0.

Change A1CR5 HP Part Number from 1902-3036 to 1920-3002, Check Digit 1.

Change ALR2 HP Part Number from 0757-0278 to 0698-7238, Check Digit 9.

Change ALR4 HP Part Number from 0811-1668 to 0811-1732, Check Digit 8.

Change C1 HP Part Number from 0180-2272 to 0180-2805, Check Digit 9.

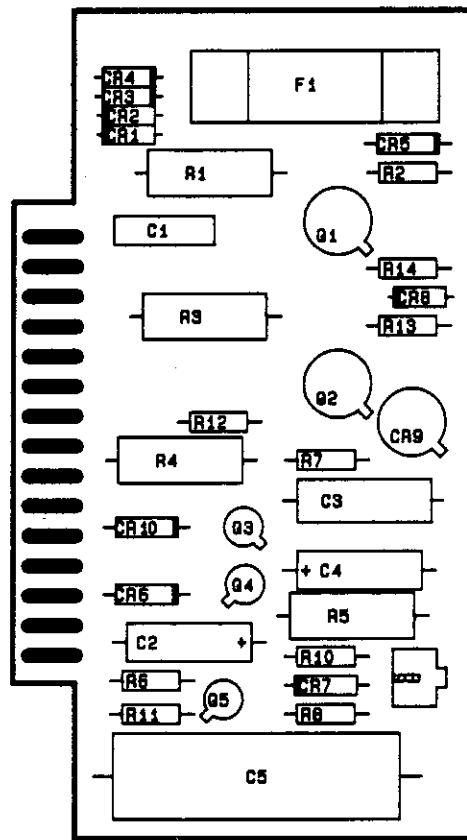

FIGURE 14. A1 POWER SUPPLY, COMPONENT LOCATIONS (ERRATA)

